

TC series

HEAVY DUTY CNC SLANT BED LATHE



FORCE ONE MACHINERY CO., LTD.

No.5, Ln. 272, Dalin Rd., Daya Dist. Taichung City 428, Taiwan

Tel: +886-4-2560 2506 Fax: +886-4-2560 2460

E-mail: sales@forceonecnc.com <http://www.forceonecnc.com>

Second Edition First print 27. FEB. 2026

TC series

HEAVY DUTY CNC SLANT BED LATHE

The design concept of TC-35/40/45/50 series CNC lathes is to improve their heavy duty cutting capabilities and high efficiency.

With large processing diameter and large spindle through hole design, it is suitable for cutting large pipes and shafts in the transportation and energy industries.



TC-40 SERIES



TC-35 SERIES

SOLID CONSTRUCTION AND EXCELLENT RIGIDITY

- Box ways on X/Z axis exhibit outstanding accuracy and load resistance capacity.
- Rigid and stable construction throughout.
- One-piece constructed bed offers the optimal bending-resistance and torsion-resistance capabilities especially when performing heavy cutting on extra large workpiece.
- The spindles on TC-35/40 series are driven by gearbox with 1:4 gear ratio. Full power output is possible when spindle speeds range 208 ~ 2,500 rpm.
- The heavy duty headstock on TC-45/50 is of one piece casting, and it is with 3 or 4 speed gear head providing extra large torque output and making the machine ideal for heavy cutting.

45 degrees slant bed construction features efficient chip removal and firm support. The major machine parts, such as the base, saddle, headstock, slide and tailstock are made of Meehanite cast iron and tempered to relieve stress thereby ensuring lifetime accuracy.

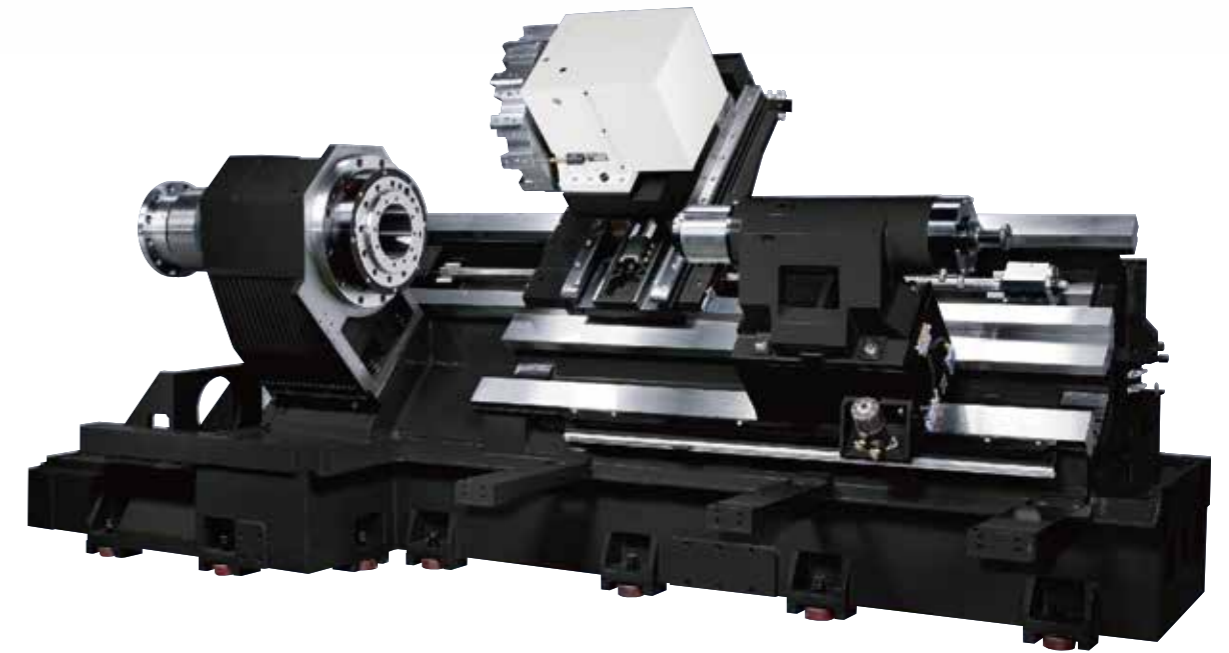

TC-35/40 Series



TC-45/50 Series

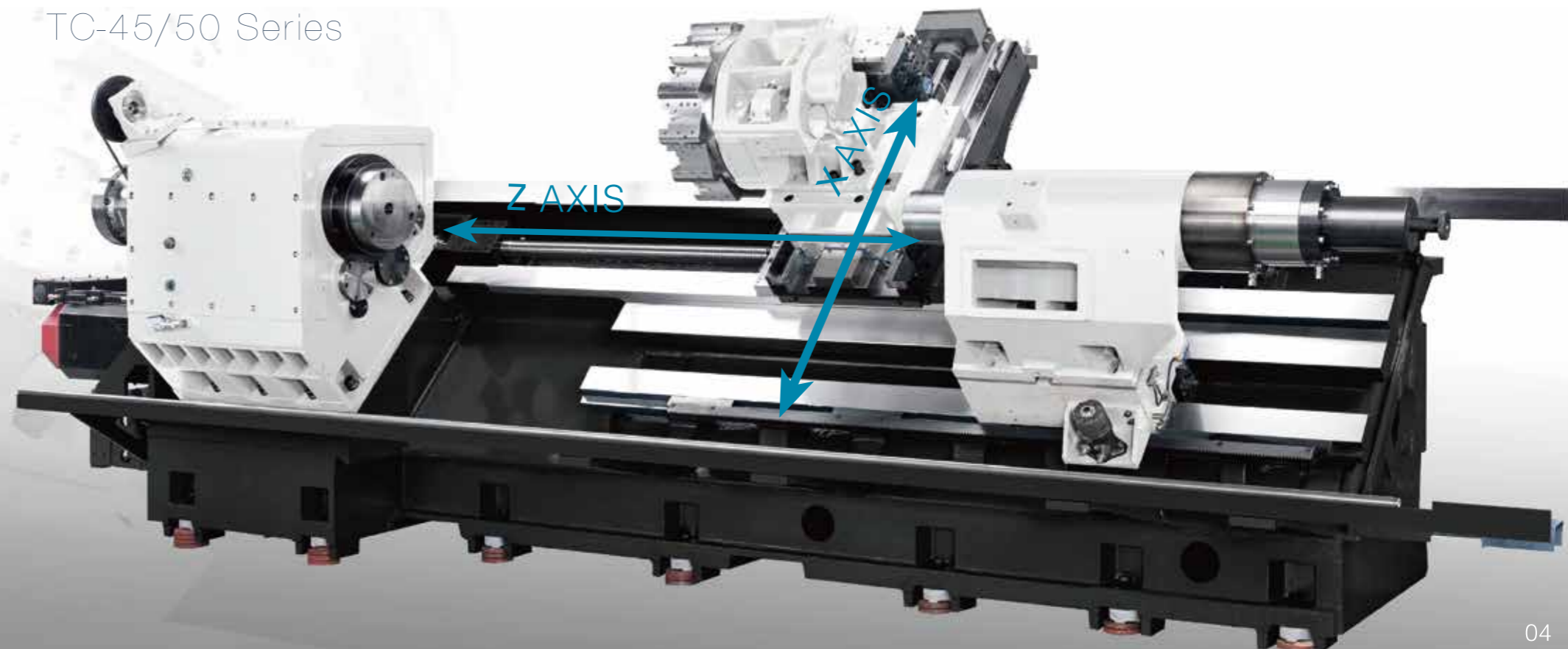

MACHINE FEATURE

Y AXIS TURRET (OPT.)

- One piece design of the Y axis base and X saddle for high-accuracy structure configuration.
- Fast indexing turret features with high repeat accuracy.
- High rigidity turret better for front and back machining.

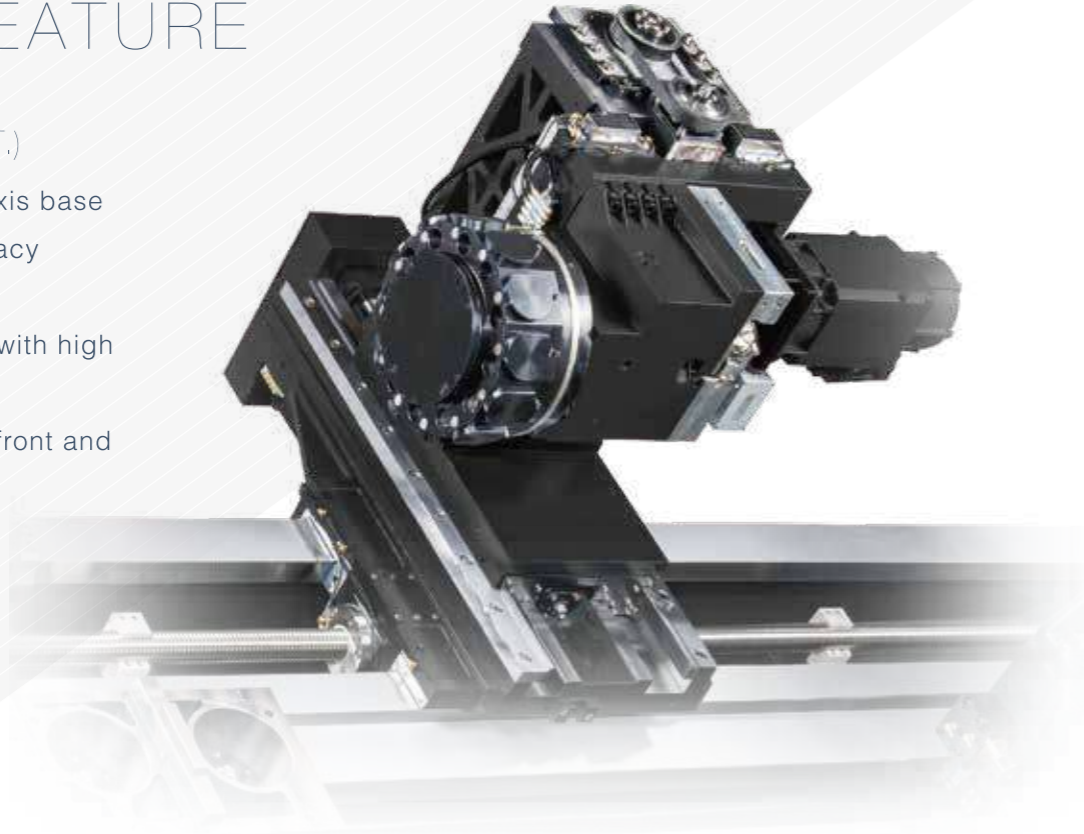

CF AXIS (OPT.)

CF axis with additional servo motor and gear box. It has better rigidity for simulation milling.



CS AXIS (OPT.)

CS axis is driven by a servo spindle motor, it is suitable for spindle indexing and milling at position.



POWER TURRET (OPT.)

- Employs VDI 50 axial turret disk, 12 position power turret. (Two PCD Inner PCD has 6 stations for milling. Outer PCD has 6 stations for turning.)
- High indexing resolution for contour/index control.
- Hydraulic disk brake locking provides maximum stability during milling and contouring.



REAR CHUCK (OPT.)



THE TELESCOPIC RUBBER COVER (OPT.)

Provides superior micro-dust protection for the track and extends the lifespan of the cover during composite material grinding operations.



POWERFUL HI-SPEED AND HI-RIGID SPINDLE (TC-35/40 series)

Spindle supported by cylindrical roller bearings and hi-speed angular thrust bearings marks the spindle faultless and ideal for heavy duty and high-speed turning.



2-STAGES SPEED GEAR BOX (TC-35/40 series)

TC-35/TC-40 series equipped with "high precision" stages gearbox (Gear ratio 1:4) provides full horsepower cutting from 208 ~ 2,500 rpm. The maximum cutting torque is 660 NM.



GEAR BOX (TC-45/50 series)

The headstock is with 3 or 4 speed gear head. Gears are precision ground for quiet running.

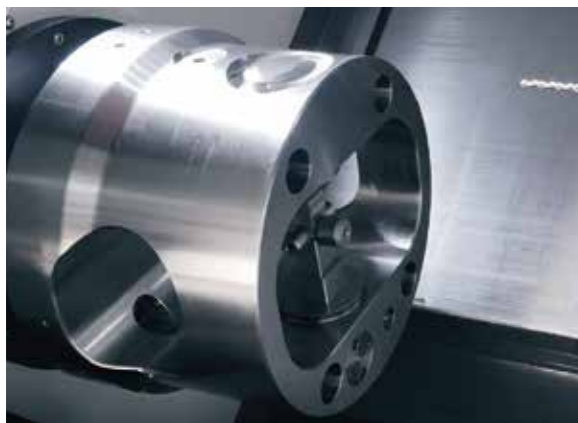

INDEX CHUCK(OPT.)

Capable of turning multi-angle machining parts, such as tees and crosses, with automatic angle adjustment and complete processing in at one time.

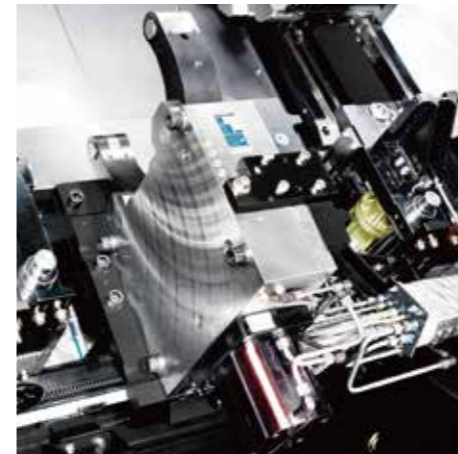

WORKPIECE PROBE



TOOL MEASURE SYSTEM Manual / Automatic swing arm.



STEADY REST (OPT.)

The manual steady rest/hydraulic power unit offers a further level of customization, allowing the incorporation of a temporary toolpost and servo driven movement functionality (To be used in conjunction with the toolpost) to meet the specific machining requirements of our customers.



WORKPIECE MEASURE SYSTEM Automatic measurement and correction of dimensions.



SPINDLE COOLER(OPT.)

The spindle cooler is designed for high-precision machining, ensuring stable temperature control to prevent overheating, which can compromise accuracy and cause equipment wear. Its efficient cooling system enhances machining stability, extends spindle lifespan, and improves productivity and product quality, making it an essential component for reliable machine operation.

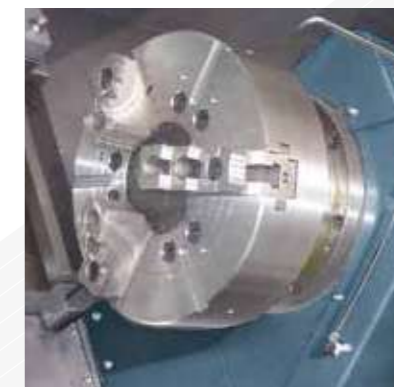

SUB SPINDLE (OPT.)

Synchronization for main and sub spindle. The workpiece can be machining at one time.

ESG (OPT.)



AUTOMATIC GREASE LUBRICATION SYSTEM

It significantly reduces lubricant usage, effectively reduces coolant tank pollution, and improves coolant quality.



VARIABLE FREQUENCY HYDRAULIC SYSTEM

Excellent energy saving effect, smaller fuel tank volume and temperature control.



SMART POWER-OFF SYSTEM

Smart power-off system temporarily limits the use of power-hungry devices during standby. After processing is completed, the system can automatically power off the equipment.

AI (OPT.)



SMART MACHINE MONITORING AND PREVENTION SYSTEM (OPT.)

Real-time spindle load monitoring is combined with artificial intelligence software technology to automatically construct a safe processing load zone, and includes intelligent tool performance management to monitor and prevent abnormalities during processing, eliminating the need for human supervision.

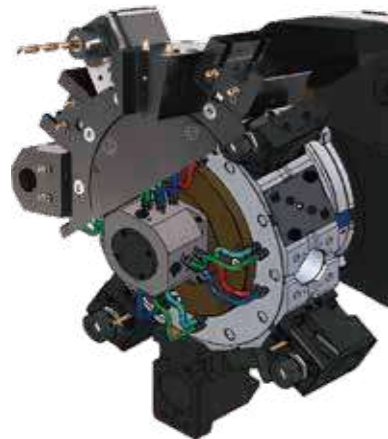

BMT & AUTO TOOL CHANGE TURRET SOLUTION (OPT.)

The BMT interface turret features a more rigid structure, supporting a wide range of live tooling options and quick-change interfaces such as Capto, enabling efficient external tool management. Additionally, we offer a hydraulic turret auto-change solution, which, when combined with a robotic arm, enables automated turret tool changing functionality.



DUST COLLECTOR (OPT.)

The dust collector is designed for efficient dust management, swiftly capturing fine particles and debris during machining to maintain a clean workspace, enhance machining accuracy, and improve operational safety. Its advanced filtration system ensures discharged air meets environmental standards, while also extending equipment lifespan, making it an ideal solution for maintaining a productive environment.



HOLLOW BALL SCREWS WITH COOLANT SYSTEM (OPT.)

The hollow ball screw cooling system can significantly reduce the thermal temperature rise position accuracy error caused by screw friction during machine movement, thereby improving the positioning accuracy of the machine.



COOLANT CONTROL SYSTEM (OPT.)

- High pressure coolant system 5/10/20/50/70 bar
- Oil skinner
- Paper filter system
- Magnetic filter system

CONTROLLER



The standard controller is FANUC, there are other controllers such as SIEMENS, MITSUMISHI, FAGOR, SYNTEC, and others you could select as optional.



OIL MIST COLLECTOR (OPT.)

The oil mist collector uses advanced separation technology to efficiently capture oil mist generated during machining, reducing air pollution and improving workshop environment quality. Recovered cutting fluids can be recycled, saving costs and extending equipment lifespan, making it the perfect blend of environmental and economic benefits.



ROTATE QUILL TAILSTOCK (OPT.)

The higher rigidity rotate quill type tailstock has bigger bearings than live center.

WORKING RANGE

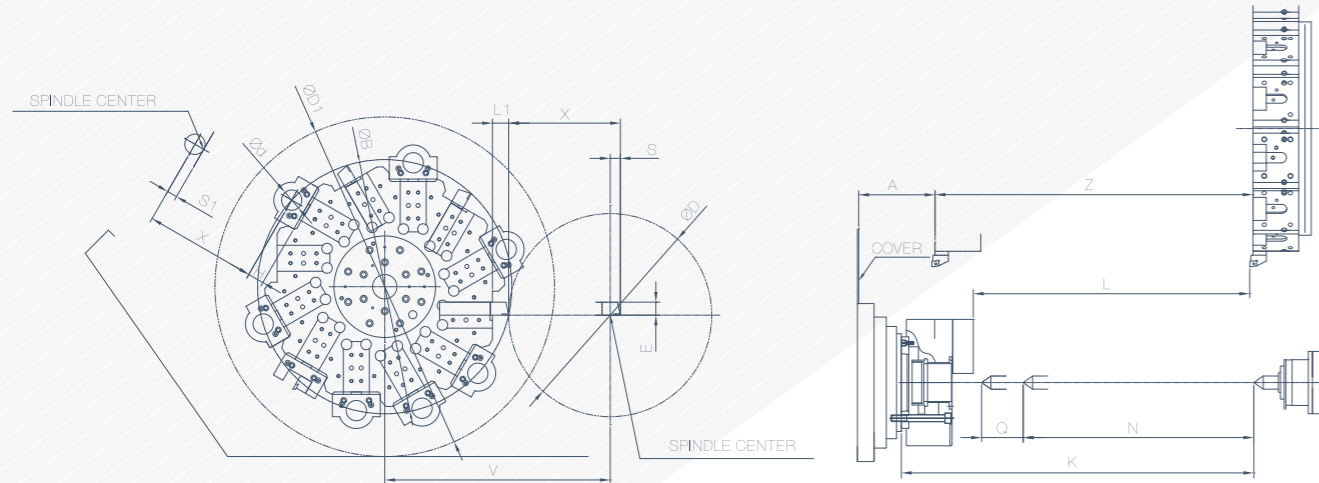

DIRECT TYPE TURRET STD.

UNIT:mm

MODEL	A	Turning D	D1	VDI d	E	H	K	Turning L	L1	N	Q	S	S1	V	Travel X	Z	B
TC-35L08	183.6	500	825	50	32	40	943	760	40	650	100	25	25	555	275	860	625.8
TC-35L15	183.6	500	825	50	32	40	1703	1520	40	1410	100	25	25	555	275	1620	625.8
TC-35L23	183.6	500	795	50	32	40	2463	2280	40	2170	100	25	25	555	275	2380	625.8
TC-35L30	183.6	500	795	50	32	40	3223	3040	40	2930	100	25	25	555	275	3140	625.8
TC-35L40	183.6	500	765	50	32	40	4223	4040	40	3930	100	25	25	555	275	4140	625.8
TC-35L50	183.6	500	735	50	32	40	5223	5040	40	4930	100	25	25	555	275	5140	625.8
TC-35L60	183.6	500	705	50	32	40	6223	6040	40	5930	100	25	25	555	275	6140	625.8
TC-35L70	183.6	500	705	50	32	40	7223	7040	40	6930	100	25	25	555	275	7140	625.8
TC-40L08	183.6	710	1025	50	32	40	943	760	40	650	100	25	25	660	380	860	625.8
TC-40L15	183.6	710	1025	50	32	40	1703	1520	40	1410	100	25	25	660	380	1620	625.8
TC-40L23	183.6	710	1025	50	32	40	2463	2280	40	2170	100	25	25	660	380	2380	625.8
TC-40L30	183.6	710	1025	50	32	40	3223	3040	40	2930	100	25	25	660	380	3140	625.8
TC-40L40	183.6	710	995	50	32	40	4223	4040	40	3930	100	25	25	660	380	4140	625.8
TC-40L50	183.6	710	965	50	32	40	5223	5040	40	4930	100	25	25	660	380	5140	625.8
TC-40L60	183.6	710	935	50	32	40	6223	6040	40	5930	100	25	25	660	380	6140	625.8
TC-40L70	183.6	710	935	50	32	40	7223	7040	40	6930	100	25	25	660	380	7140	625.8
TC-45L12	235	850	910	50	32	40	1569.5	1130	40	950	200	25	25	730	450	1250	625.8
TC-45L17	235	850	910	50	32	40	2060.5	1630	40	1450	200	25	25	730	450	1750	625.8
TC-45L22	235	850	910	50	32	40	2569.5	2130	40	1950	200	25	25	730	450	2250	625.8
TC-45L32	235	850	880	50	32	40	3529.5	3090	40	2910	200	25	25	730	450	3210	625.8
TC-45L42	235	850	850	50	32	40	4469.5	4030	40	3850	200	25	25	730	450	4150	625.8
TC-45L52	235	850	820	50	32	40	5469.5	5030	40	4850	200	25	25	730	450	5150	625.8
TC-45L62	235	850	790	50	32	40	6469.5	6030	40	5850	200	25	25	730	450	6150	625.8
TC-45L72	235	850	760	50	32	40	7469.5	7030	40	6850	200	25	25	730	450	7150	625.8
TC-50L22	192.5	1020	1120	50	32	40	2383	2150	40	1900	200	25	25	815	535	2260	625.8
TC-50L32	192.5	1020	1090	50	32	40	3373	3140	40	2900	200	25	25	815	535	3220	625.8
TC-50L42	192.5	1020	1060	50	32	40	4308	4075	40	3900	200	25	25	815	535	4090	625.8
TC-50L52	192.5	1020	1030	50	32	40	5290	5057	40	4900	200	25	25	815	535	5070	625.8
TC-50L62	192.5	1020	1000	50	32	40	6290	6057	40	5900	200	25	25	815	535	6070	625.8
TC-50L72	192.5	1020	970	50	32	40	7290	7057	40	6900	200	25	25	815	535	7070	625.8

- All specification, design and characteristics shown on this catalogue are subject to change without prior notice.
- The BMT Turret is available

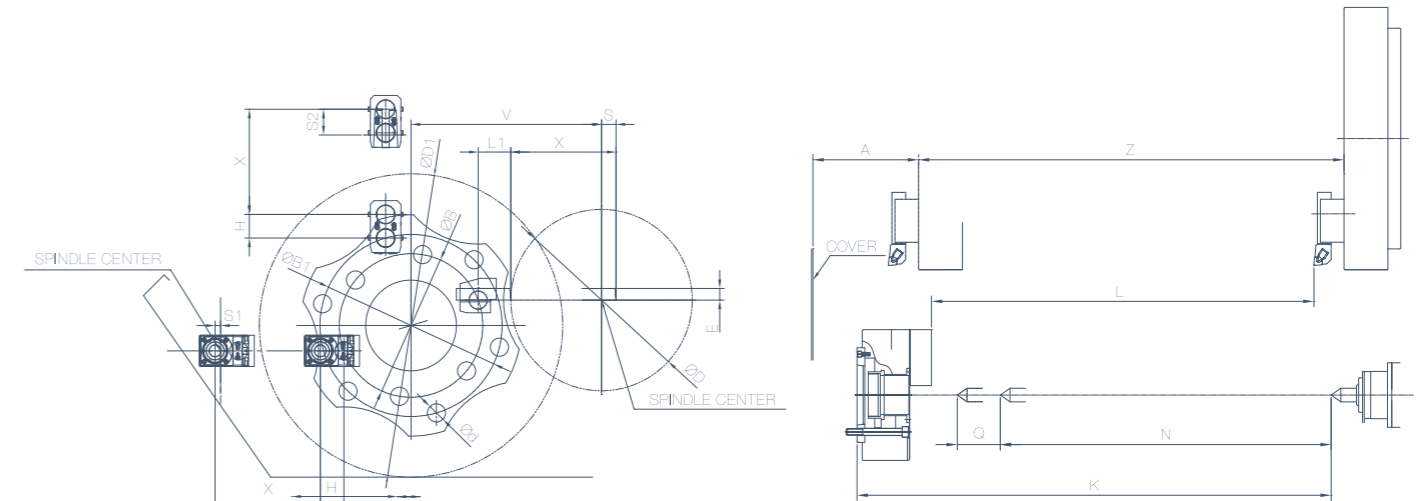

POWER TURRET VDI AXIAL MOUNTING OPT.

UNIT:mm

MODEL	A	Turning D	D1	VDI d	E	H	K	Turning L	L1	N	Q	S	S1	S2	V	Travel X	Z	B	B1
TC-35L08	245.7	500	825	50	32	65	919	706	90	596	100	40	15	71	525	290	806	395.6	501.9
TC-35L15	245.7	500	825	50	32	65	1679	1466	90	1356	100	40	15	71	525	290	1566	395.6	501.9
TC-35L23	245.7	500	795	50	32	65	2439	2226	90	2116	100	40	15	71	525	290	2326	395.6	501.9
TC-35L30	245.7	500	795	50	32	65	3199	2986	90	2876	100	40	15	71	525	290	3086	395.6	501.9
TC-35L40	245.7	500	765	50	32	65	4199	3986	90	3876	100	40	15	71	525	290	4086	395.6	501.9
TC-35L50	245.7	500	735	50	32	65	5199	4986	90	4876	100	40	15	71	525	290	5086	395.6	501.9
TC-35L60	245.7	500	705	50	32	65	6199	5986	90	5876	100	40	15	71	525	290	6086	395.6	501.9
TC-35L70	245.7	500	705	50	32	65	7199	6986	90	6876	100	40	15	71	525	290	7086	395.6	501.9
TC-40L08	245.7	710	1025	50	32	65	919	706	90	596	100	40	15	71	525	395	806	395.6	501.9
TC-40L15	245.7	710	1025	50	32	65	1679	1466	90	1356	100	40	15	71	630	395	1566	395.6	501.9
TC-40L23	245.7	710	1025	50	32	65	2439	2226	90	2116	100	40	15	71	630	395	2326	395.6	501.9
TC-40L30	245.7	710	1025	50	32	65	3199	2986	90	2876	100	40	15	71	630	395	3086	395.6	501.9
TC-40L40	245.7	710	995	50	32	65	4199	3986	90	3876	100	40	15	71	630	395	4086	395.6	501.9
TC-40L50	245.7	710	965	50	32	65	5199	4986	90	4876	100	40	15	71	630	395	5086	395.6	501.9
TC-40L60	245.7	710	935	50	32	65	6199	5986	90	5876	100	40	15	71	630	395	6086	395.6	501.9
TC-40L70	245.7	710	935	50	32	65	7199	6986	90	6876	100	40	15	71	630	395	7086	395.6	501.9
TC-45L12	283.1	850	910	50	32	65	1449.1	1116	95	1060	200	45	15	71	705	470	1250	395.6	501.9
TC-45L17	283.1	850	910	50	32	65	1949.1	1616	95	1560	200	45	15	71	705	470	1750	395.6	501.9
TC-45L22	283.1	850	910	50	32	65	2449.1	2116	95	2060	200	45	15	71	705	470	2250	395.6	501.9
TC-45L32	283.1	850	880	50	32	65	3409.1	3076	95	3020	200	45	15	71	705	470	3210	395.6	501.9
TC-45L42	283.1	850	850	50	32	65	4483.1	4030	95	3960	200	45	15	71	705	470	4150	395.6	501.9
TC-45L52	283.1	850	820	50	32	65	5483.1	5030	95	4960	200	45	15	71	705	470	5150	395.6	501.9
TC-45L62	283.1	850	790	50	32	65	6483.1	6030	95	5960	200	45	15	71	705	470	6150	395.6	501.9
TC-45L72	283.1	850	760	50	32	65	7483.1	7030	95	6960	200	45	15	71	705	470	7150	395.6	501.9

- All specification, design and characteristics shown on this catalogue are subject to change without prior notice.
- The BMT Turret is available

WORKING RANGE

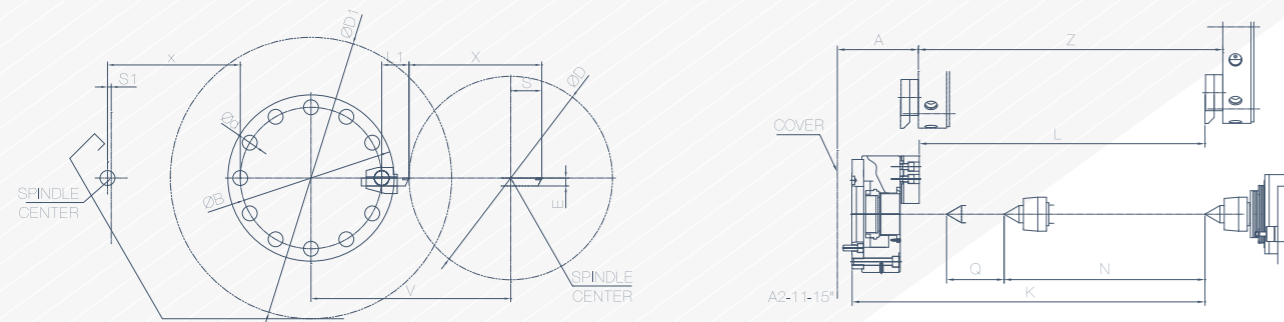

POWER TURRET VDI AXIAL MOUNTING OPT TC-50L22 ~ TC-50L72 UNIT:mm

MODEL	A	Turning D	D1	VDI d	E	H	K	L	L1	N	Q	S	S1	V	Travel X	Z	B
TC-50L22	281.5	820	1120	60	32	-	2428	2195	47.5	1900	200	47.5	15	805	535	2260	570
TC-50L32	281.5	820	1090	60	32	-	3418	3185	47.5	2900	200	47.5	15	805	535	3220	570
TC-50L42	281.5	820	1060	60	32	-	4353	4120	47.5	3900	200	47.5	15	805	535	4090	570
TC-50L52	281.5	820	1030	60	32	-	5335	5102	47.5	4900	200	47.5	15	805	535	5070	570
TC-50L62	281.5	820	1000	60	32	-	6335	6102	47.5	5900	200	47.5	15	805	535	6070	570
TC-50L72	281.5	820	970	60	32	-	7335	7102	47.5	6900	200	47.5	15	805	535	7070	570

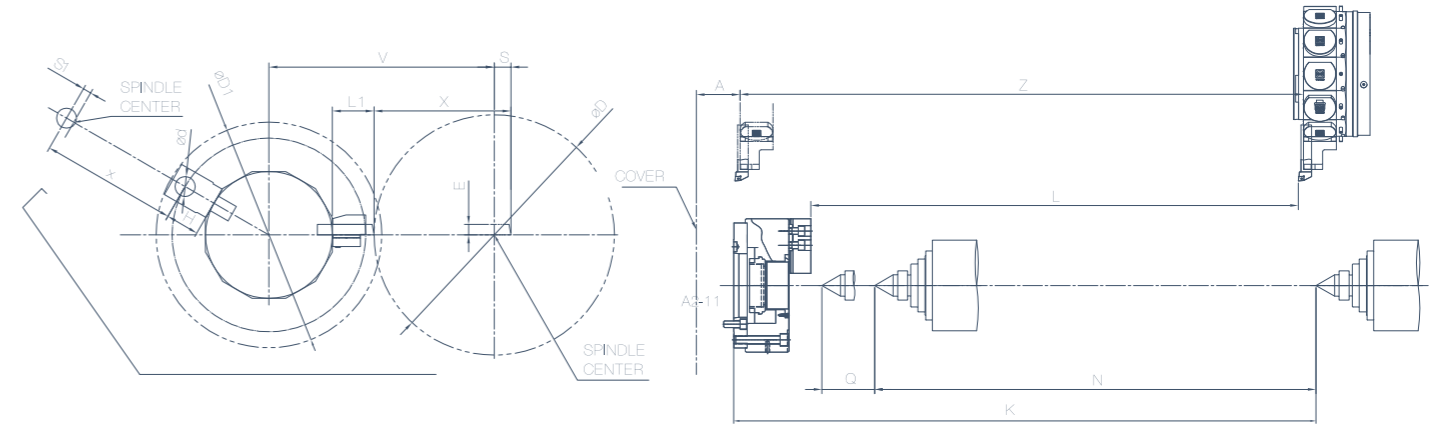

POWER TURRET BMT AXIAL MOUNTING OPT UNIT:mm

MODEL	A	Turning Dia D	D1	BMT d	E	H	K	Turning L	L1	N	Q	S	S1	V	Travel X	Z
TC-35L08	180	646	720	75	32	90	939	687	145	650	100	72	17	578	290	860
TC-35L15	180	646	720	75	32	90	1699	1447	145	1410	100	72	17	578	290	1620
TC-35L23	180	646	720	75	32	90	2459	2207	145	2170	100	72	17	578	290	2380
TC-35L30	180	646	720	75	32	90	3219	2967	145	2930	100	72	17	578	290	3140
TC-35L40	180	646	720	75	32	90	4219	3967	145	3930	100	72	17	578	290	4140
TC-35L50	180	646	720	75	32	90	5219	4967	145	4930	100	72	17	578	290	5140
TC-35L60	180	646	720	75	32	90	6219	5967	145	5930	100	72	17	578	290	6140
TC-35L70	180	646	720	75	32	90	7219	6967	145	6930	100	72	17	578	290	7140
TC-40L08	180	646	720	75	32	90	939	687	145	650	100	72	17	683	395	860
TC-40L15	180	646	720	75	32	90	1699	1447	145	1410	100	72	17	683	395	1620
TC-40L23	180	646	720	75	32	90	2459	2207	145	2170	100	72	17	683	395	2380
TC-40L30	180	646	720	75	32	90	3219	2967	145	2930	100	72	17	683	395	3140
TC-40L40	180	646	720	75	32	90	4219	3967	145	3930	100	72	17	683	395	4140
TC-40L50	180	646	720	75	32	90	5219	4967	145	4930	100	72	17	683	395	5140
TC-40L60	180	646	720	75	32	90	6219	5967	145	5930	100	72	17	683	395	6140
TC-40L70	180	646	720	75	32	90	7219	6967	145	6930	100	72	17	683	395	7140
TC-45L12	104	630	860	85	32	110	1429	1054	130	950	160	85	65	710	400	1250
TC-45L17	104	630	860	85	32	110	1929	1554	130	1450	160	85	65	710	400	1750
TC-45L22	104	630	860	85	32	110	2429	2054	130	1950	160	85	65	710	400	2250
TC-45L32	104	630	860	85	32	110	3389	3014	130	2910	160	85	65	710	400	3210
TC-45L42	104	630	860	85	32	110	4329	3954	130	3850	160	85	65	710	400	4150
TC-45L52	104	630	860	85	32	110	5329	4954	130	4850	160	85	65	710	400	5150
TC-45L62	104	630	860	85	32	110	6329	5954	130	5850	160	85	65	710	400	6150
TC-45L72	104	630	860	85	32	110	7329	6954	130	6850	160	85	65	710	400	7150
TC-50L22	192.5	970	860	85	32	110	2383	2152	130	1900	200	50	30	880	535	2260
TC-50L32	192.5	970	860	85	32	110	3343	3112	130	2860	200	50	30	880	535	3220
TC-50L42	192.5	970	860	85	32	110	4213	3982	130	3730	200	50	30	880	535	4090
TC-50L52	192.5	970	860	85	32	110	5193	4962	130	4710	200	50	30	880	535	5070
TC-50L62	192.5	970	860	85	32	110	6193	6962	130	5710	200	50	30	880	535	6070
TC-50L72	192.5	970	860	85	32	110	7193	7962	130	6710	200	50	30	880	535	7070

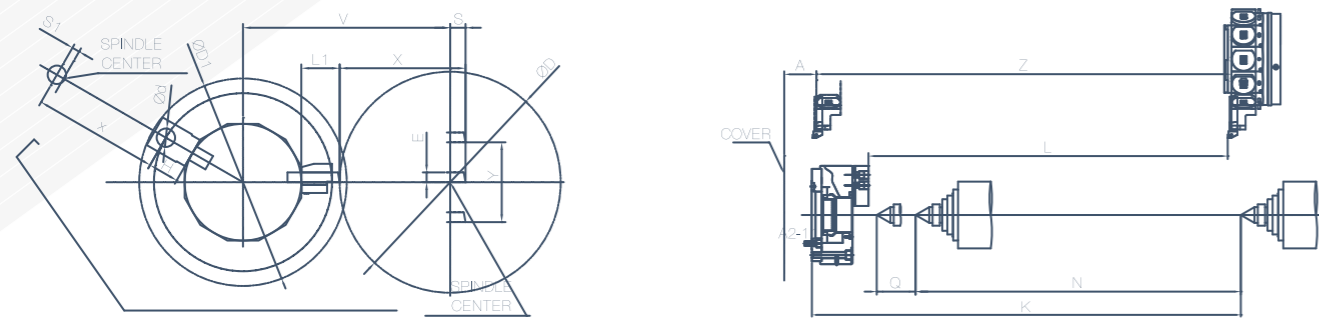

POWER TURRET VDI AXIAL MOUNTING OPT. UNIT: mm

MODEL	A	Turning Dia D	D1	VDI d	E	H	K	Turning L	L1	N	Q	S	S1	V	Travel X	Z	Y
TC-40YL08	189.6	590	1025	40	25	100	943	682	120	512	100	40	20	575	335	783	+/-80
TC-40YL15	189.6	590	1025	40	25	100	1703	1442	120	1272	100	40	20	575	335	1543	+/-80
TC-40YL23	189.6	590	1025	40	25	100	2463	2202	120	2032	100	40	20	575	335	2303	+/-80
TC-40YL30	189.6	590	1025	40	25	100	3223	2962	120	2792	100	40	20	575	335	3063	+/-80
TC-40YL40	189.6	590	995	40	25	100	4223	3962	120	3792	100	40	20	575	335	4063	+/-80
TC-40YL50	189.6	590	965	40	25	100	5223	4962	120	4792	100	40	20	575	335	5063	+/-80
TC-40YL60	189.6	590	935	40	25	100	6223	5962	120	5792	100	40	20	575	335	6063	+/-130
TC-45YL12	132.6	720	910	50	32	100	1569.5	980	125	840	160	50	25	675	410	1210	+/-130
TC-45YL17	132.6	720	910	50	32	100	2060.5	1480	125	1340	160	50	25	675	410	1710	+/-130
TC-45YL22	132.6	720	910	50	32	100	2569.5	1980	125	1840	160	50	25	675	410	2210	+/-130
TC-45YL32	132.6	720	880	50	32	100	3529.5	2940	125	2800	160	50	25	675	410	3170	+/-130
TC-45YL42	132.6	720	850	50	32	100	4469.5	3880	125	3740	160	50	25	675	410	4110	+/-130
TC-45YL52	132.6	720	820	50	32	100	5469.5	4880	125	4740	160	50	25	675	410	5110	+/-130
TC-45YL62	132.6	720	790	50	32	100	6469.5	5880	125	5740	160	50	25	675	410	6110	+/-130
TC-45YL72	132.6	720	760	50	32	100	7469.5	6880	125	6740	160	50	25	675	410	7110	+/-130

- All specification, design and characteristics shown on this catalogue are subject to change without prior notice.
 - The BMT Turret is available

WORKING RANGE

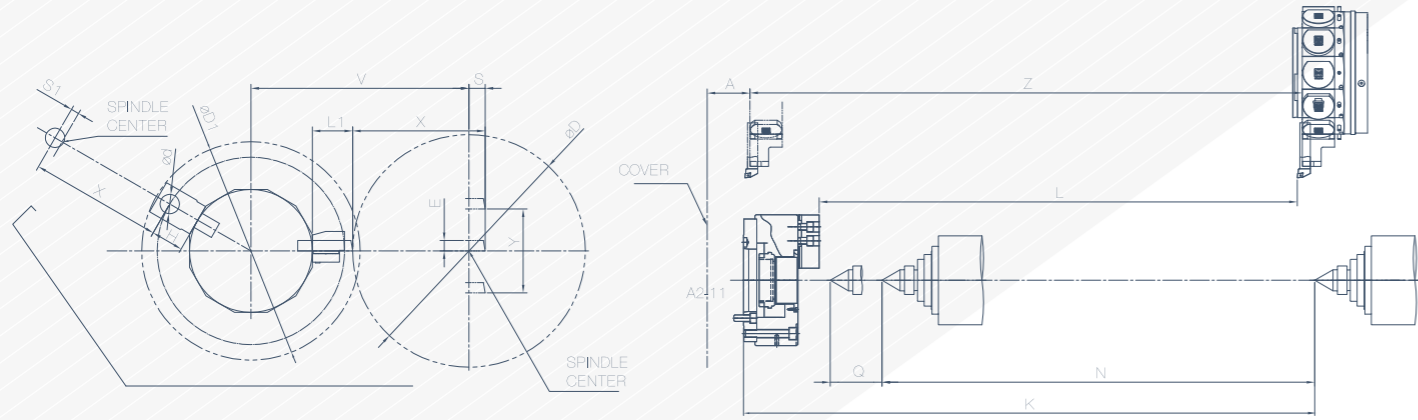

TC-40/45/50-Y-POWER TURRET BMT AXIAL MOUNTING OPT UNIT:mm

MODEL	A	Turning Dia D	D1	BMTd	E	H	K	Turning L	L1	N	Q	S	S1	V	Travel X	Z	Y
TC-40YL08	261	500	610	65	25	72	865	654	115	512	100	65	22	555	315	755	+/-80
TC-40YL15	261	500	610	65	25	72	1625	1414	115	1272	100	65	22	555	315	1515	+/-80
TC-40YL23	261	500	610	65	25	72	2385	2714	115	2032	100	65	22	555	315	2275	+/-80
TC-40YL30	261	500	610	65	25	72	3145	2934	115	2792	100	65	22	555	315	3035	+/-80
TC-40YL40	261	500	610	65	25	72	4145	3934	115	3792	100	65	22	555	315	4035	+/-80
TC-40YL50	261	500	610	65	25	72	5145	4934	115	4792	100	65	22	555	315	5035	+/-80
TC-40YL60	261	500	610	65	25	72	6145	5934	115	5792	100	65	22	555	315	6035	+/-130
TC-40YL70	261	500	610	65	25	72	7145	6934	115	6792	100	65	22	555	315	7035	+/-130
TC-45YL12	80	630	720	75	32	90	1429	1030	145	950	160	95	40	675	410	1250	+/-130
TC-45YL17	80	630	720	75	32	90	1929	1530	145	1450	160	95	40	675	410	1750	+/-130
TC-45YL22	80	630	720	75	32	90	2429	2030	145	1950	160	95	40	675	410	2250	+/-130
TC-45YL32	80	630	720	75	32	90	3389	2990	145	2910	160	95	40	675	410	3210	+/-130
TC-45YL42	80	630	720	75	32	90	4329	3930	145	3850	160	95	40	675	410	4150	+/-130
TC-45YL52	80	630	720	75	32	90	5329	4930	145	4850	160	95	40	675	410	5150	+/-130
TC-45YL62	80	630	720	75	32	90	6329	5930	145	5850	160	95	40	675	410	6150	+/-130
TC-45YL72	80	630	720	75	32	90	7329	6930	145	6850	160	95	40	675	410	7150	+/-130
TC-50YL22	130.5	810	720	75	32	90	2383	2030	145	1900	200	80	25	765	485	2200	+/-130
TC-50YL32	130.5	810	720	75	32	90	3343	2990	145	2860	200	80	25	765	485	3160	+/-130
TC-50YL42	130.5	810	720	75	32	90	4213	3860	145	3730	200	80	25	765	485	4030	+/-130
TC-50YL52	130.5	810	720	75	32	90	5193	4840	145	4710	200	80	25	765	485	5010	+/-130
TC-50YL62	130.5	810	720	75	32	90	6193	5840	145	5710	200	80	25	765	485	6010	+/-130
TC-50YL72	130.5	810	720	75	32	90	7193	6840	145	6710	200	80	25	765	485	7010	+/-130

INTERFERENCE

MODEL : TC-40T2

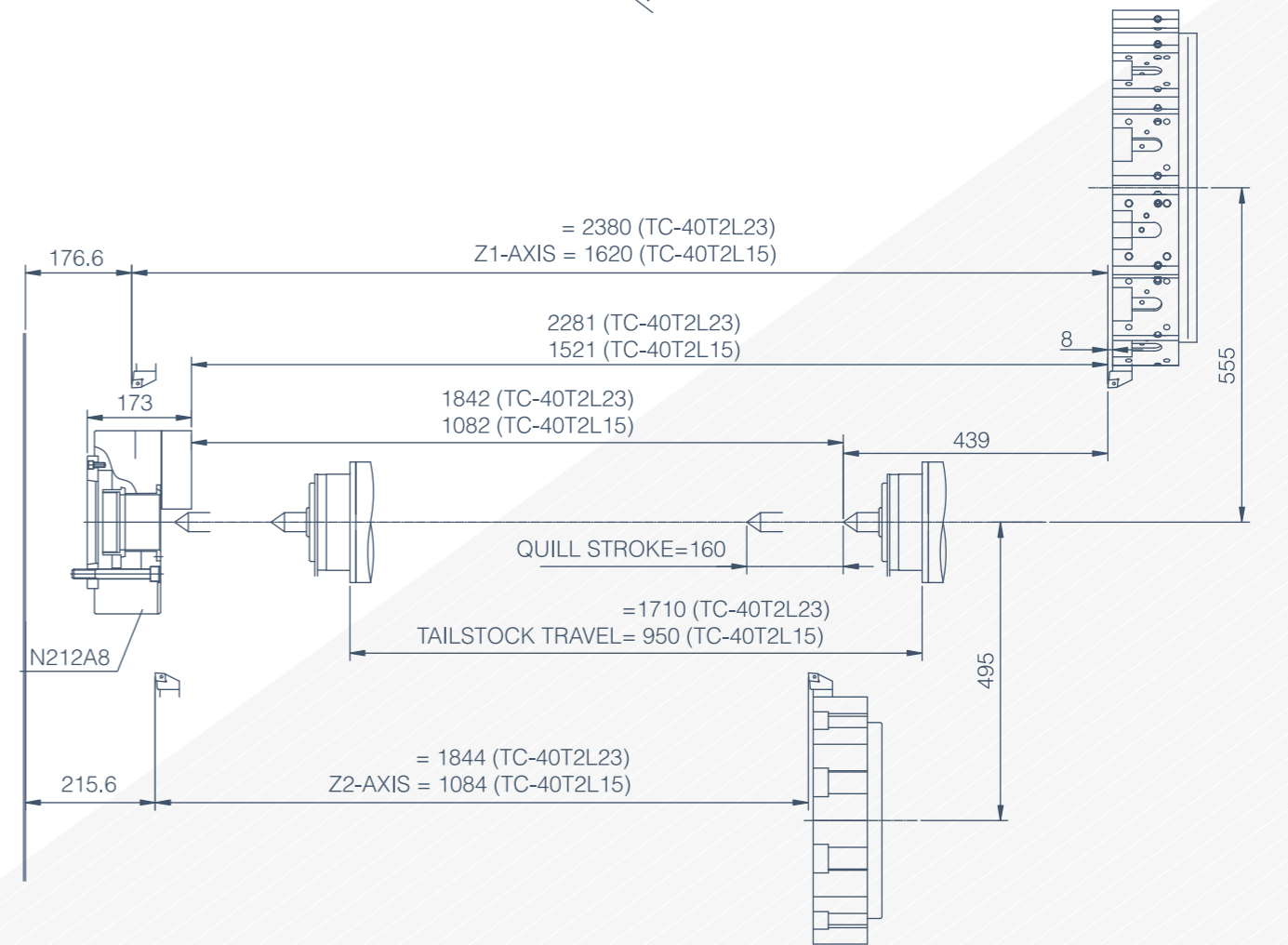
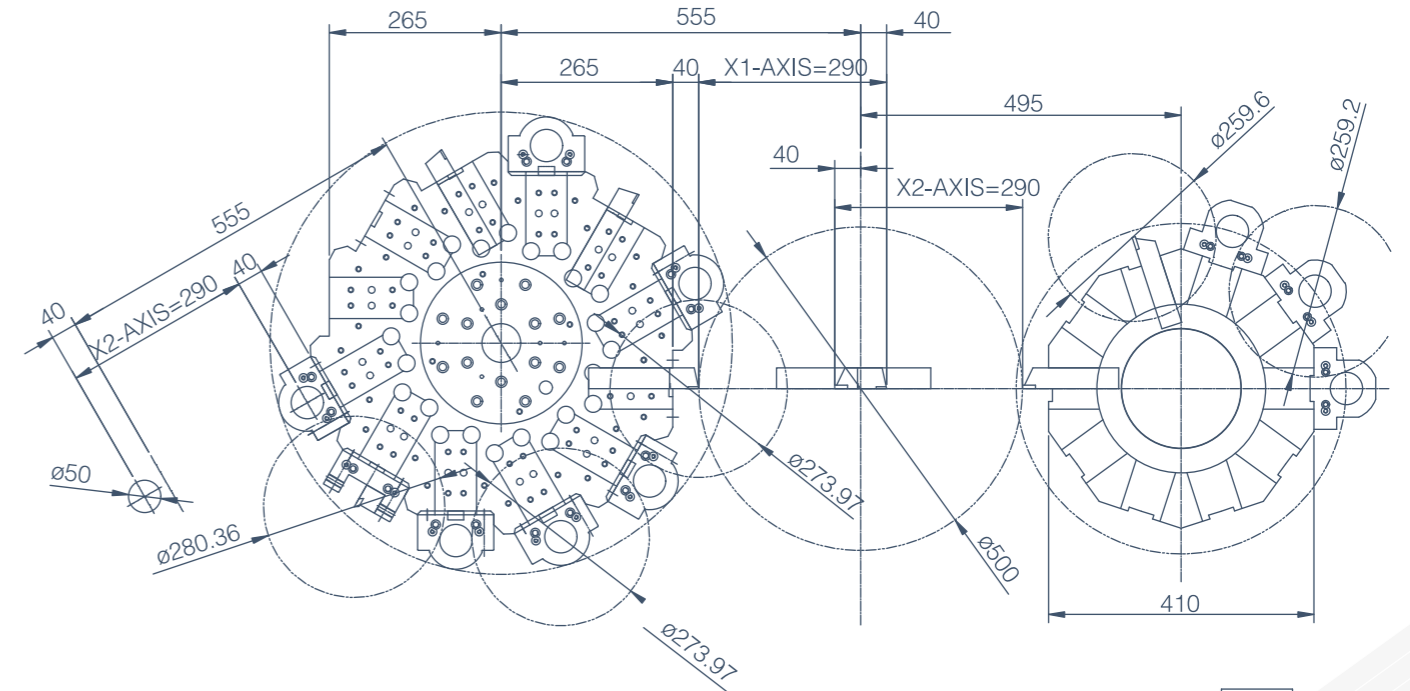

TOOLING SYSTEM

DIRECT TYPE
TURRET STD.

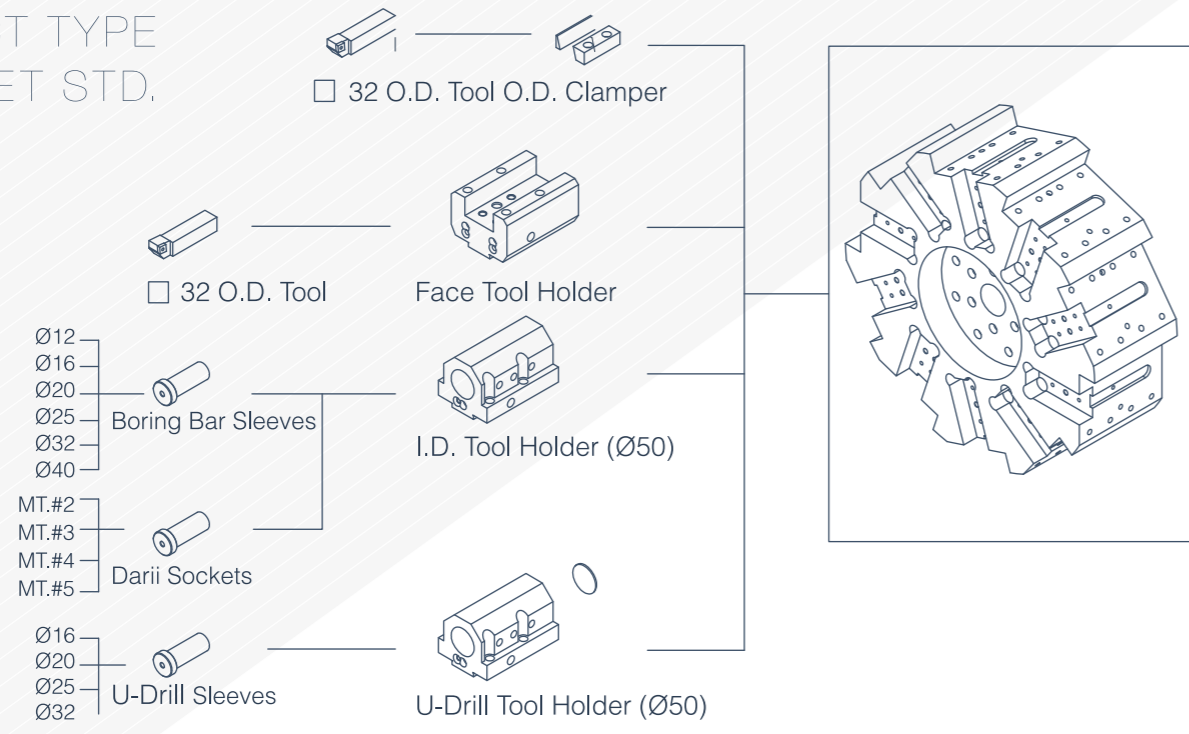

FOR TC-50

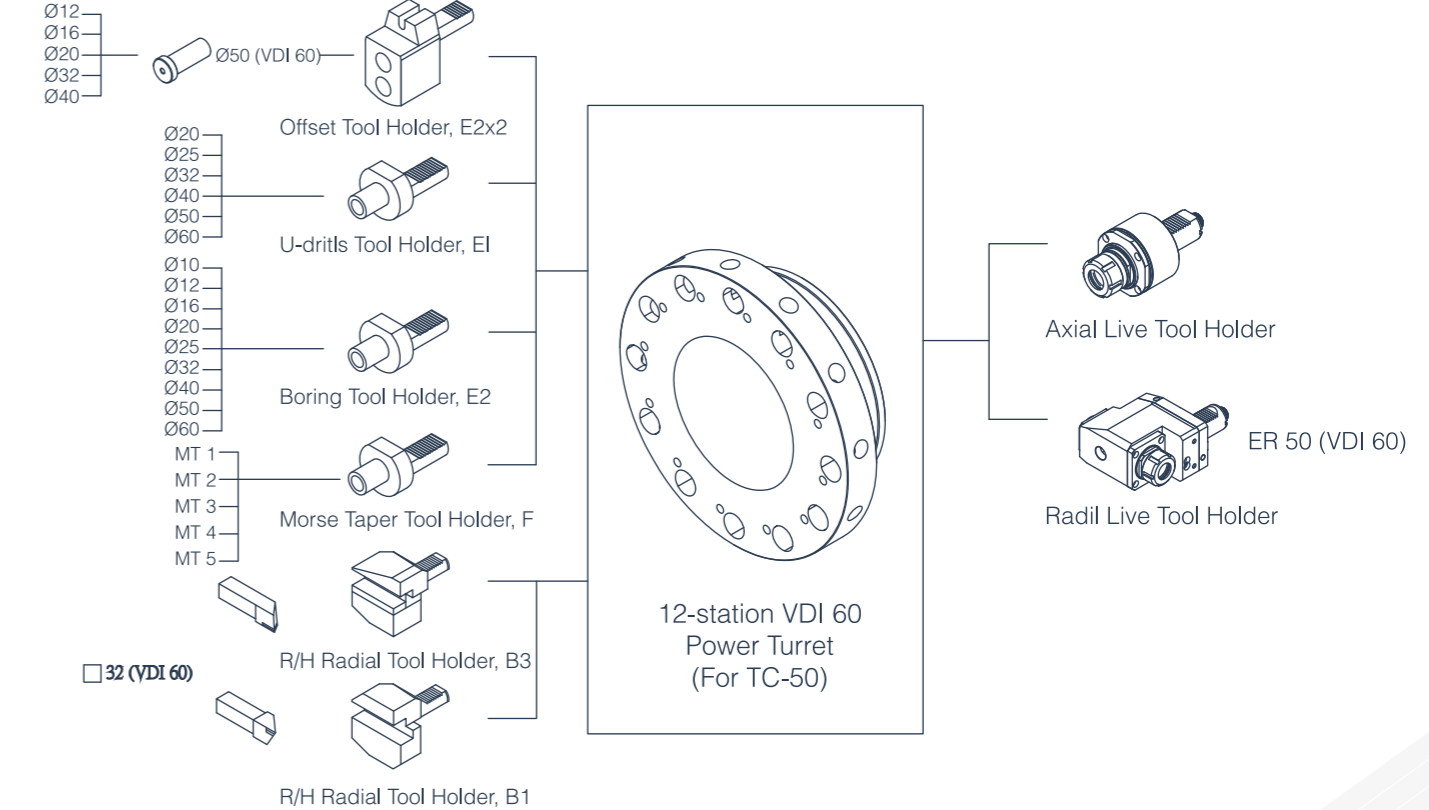

VDI AXIAL TYPE OPT.
FOR TC-35/TC-40/TC-45

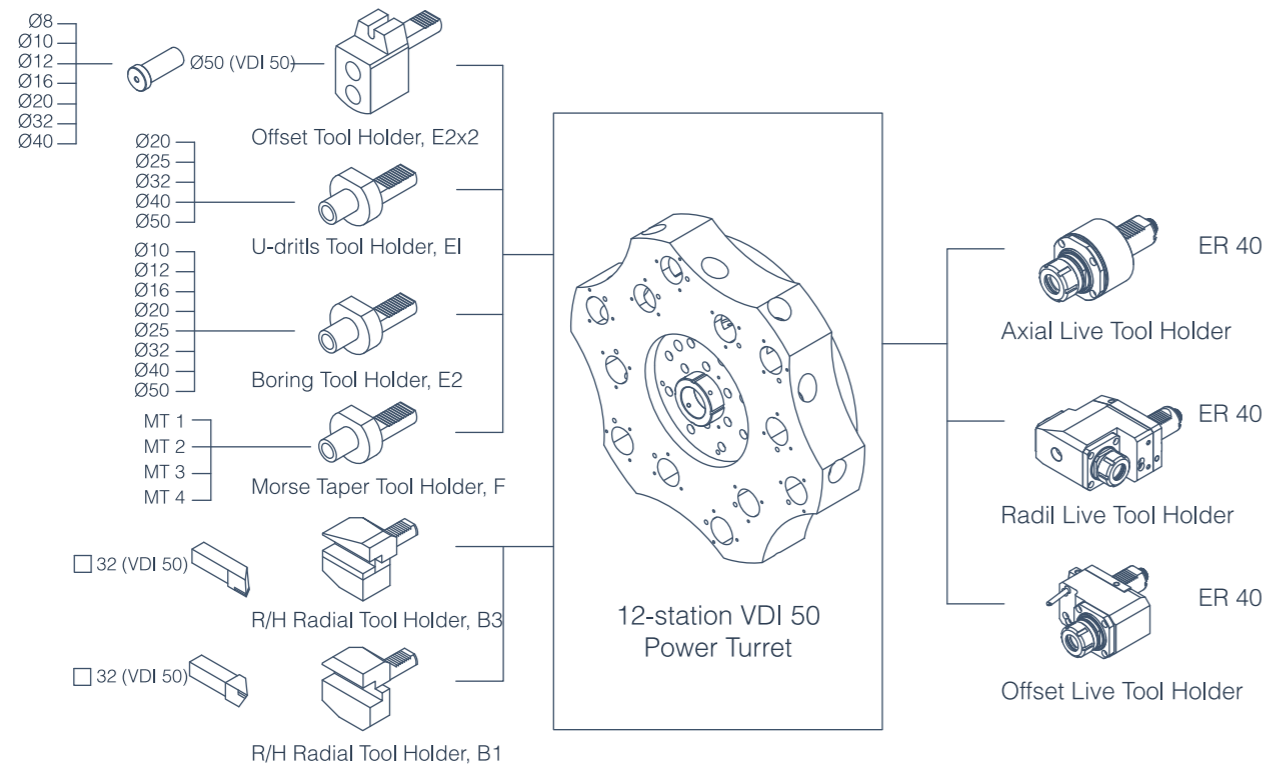

VDI RADIAL TYPE OPT.

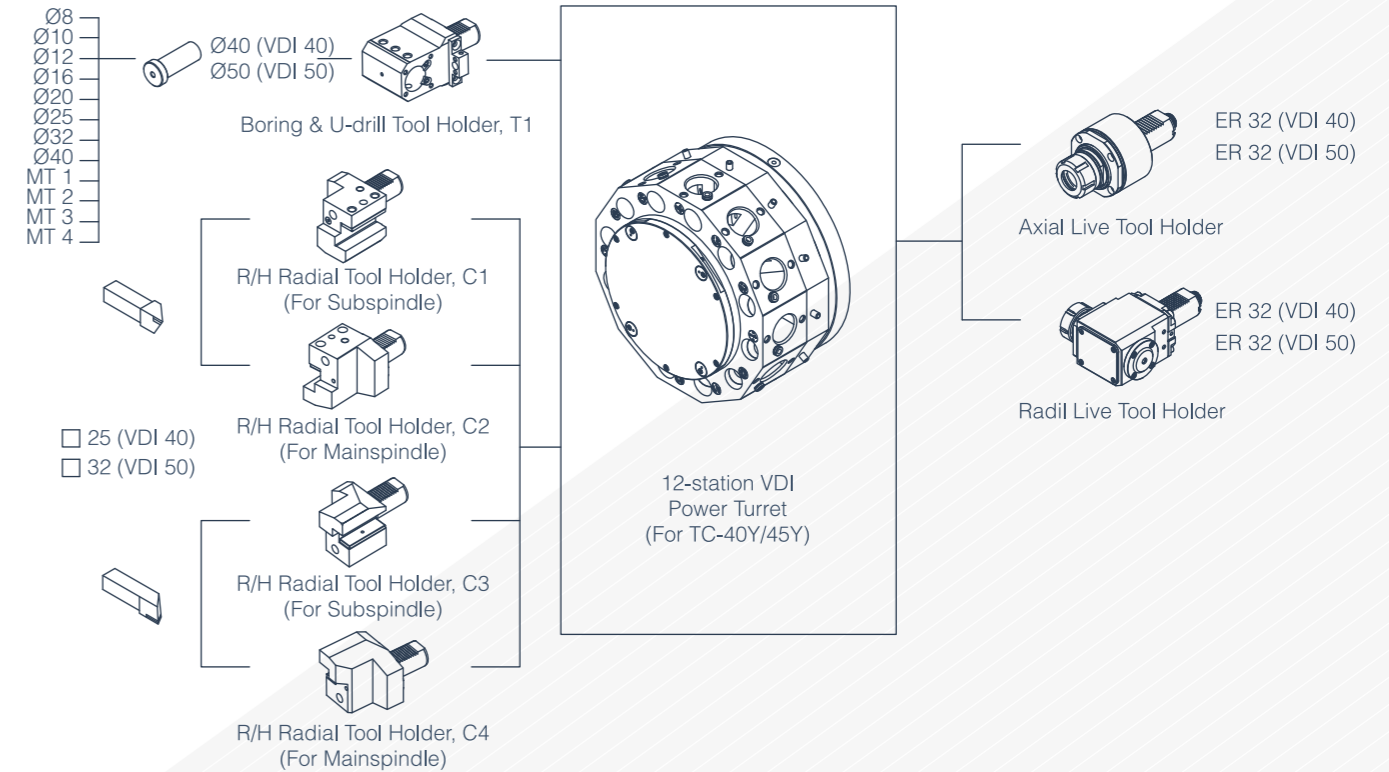

BMT TYPE OPT. The drawing will be provide by the requirement.

- All specification, design and characteristics shown on this catalogue are subject to change without prior notice.

- All specification, design and characteristics shown on this catalogue are subject to change without prior notice.

DIMENSIONAL DRAWINGS

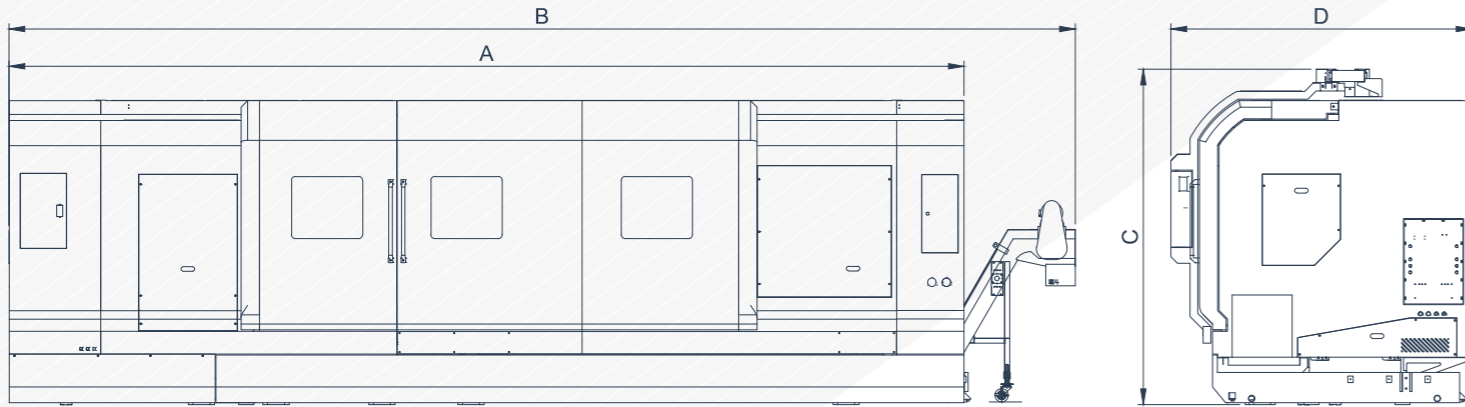

MODEL	A (mm)	B (mm)	C (mm)	D (mm)	W (kg)
TC-35L08	5304	6154	2235	2130	10030
TC-35L15	6064	6914	2235	2130	11300
TC-35L23	6824	7674	2235	2130	13700
TC-35L30	7584	8434	2565	2290	16300
TC-35L40	8155	9005	2565	2290	17500
TC-35L50	9300	10150	2565	2290	19000
TC-35L60	10325	11215	2565	2290	21000
TC-35L70	11700	12590	2565	2290	24500
TC-40L08	5304	6154	2235	2130	11500
TC-40YL08	3800	4650	2650	2200	13000
TC-40L15	6064	6914	2235	2130	12100
TC-40YL15	4500	5350	2650	2200	14500
TC-40L23	6824	7674	2235	2130	15600
TC-40YL23	5300	6150	2650	2200	16000
TC-40L30	7584	8434	2565	2290	17900
TC-40YL30	6000	6850	3000	2550	17500
TC-40L40	8155	9005	2565	2290	19500
TC-40YL40	7000	7850	3000	2550	21000
TC-40L50	9300	10150	2565	2290	21200
TC-40YL50	8000	8850	3000	2550	24000
TC-40L60	10325	11175	2565	2290	23000
TC-40YL60	9000	9850	3000	2550	27000
TC-40L70	11700	12550	2565	2290	26500
TC-40YL70	10375	11225	3000	2550	30500

MODEL	A (mm)	B (mm)	C (mm)	D (mm)	W (kg)
TC-45L12	6160	7010	2445	2230	14200
TC-45YL12	5440	6290	2760	2250	14000
TC-45L17	6660	7510	2445	2230	14950
TC-45YL17	5940	6790	2760	2250	15550
TC-45L22	7160	8010	2445	2230	15700
TC-45YL22	6440	7290	3090	2250	17090
TC-45L32	8160	9010	2775	2390	18400
TC-45YL32	7440	8290	3090	2570	20200
TC-45L42	9160	10010	2775	2390	20100
TC-45YL42	8440	9290	3090	2570	23300
TC-45L52	10160	11010	2775	2390	21900
TC-45YL52	9440	10290	3090	2570	26400
TC-45L62	11160	12010	2850	2465	23700
TC-45YL62	10440	11290	3165	2645	29500
TC-45L72	12160	13010	2925	2540	25500
TC-45YL72	11440	12290	3240	2720	32600
TC-50L22	8700	9550	3050	3158	18000
TC-50YL22	6440	7290	3090	2570	18500
TC-50L32	9700	10550	3380	3318	23000
TC-50YL32	7440	8290	3090	2570	23500
TC-50L42	10700	11550	3380	3318	27000
TC-50YL42	8440	9290	3090	2570	27500
TC-50L52	11700	12550	3380	3318	32000
TC-50YL52	9440	10290	3090	2570	32500
TC-50L62	12700	13550	3455	3393	37000
TC-50YL62	10440	11290	3090	2570	37500
TC-50L72	13700	14550	3530	3468	42000
TC-50YL72	11440	12290	3090	2570	42500

SPINDLE OUTPUT / TORQUE DIAGRAM

TC-35
TC-40

Spindle: A2-8
Spindle bore: $\Phi 105\text{mm}$
Spindle gearbox: 2-speed
Spindle motor: $\alpha 22i(22/26\text{kW})$

Spindle: A2-11
Spindle bore: $\Phi 131\text{mm}$
Spindle gearbox: 2-speed
Spindle motor: $\alpha 22i(22/26\text{kW})$

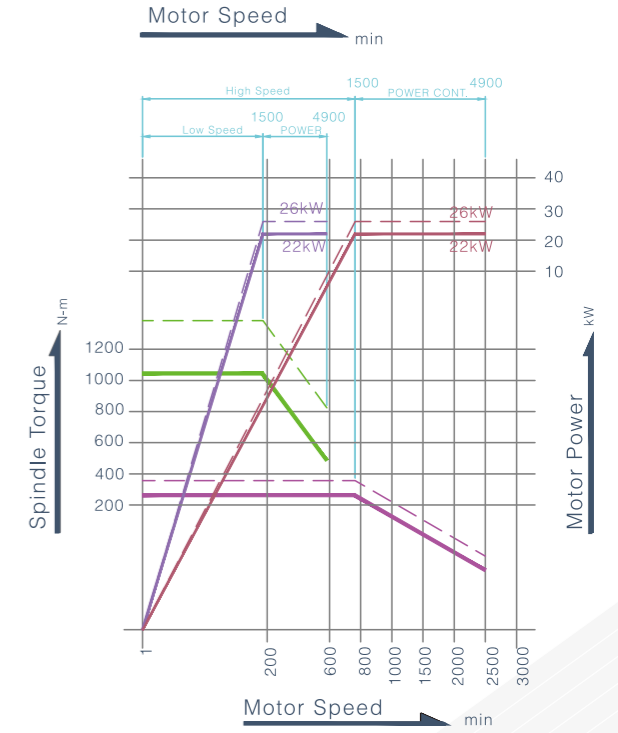
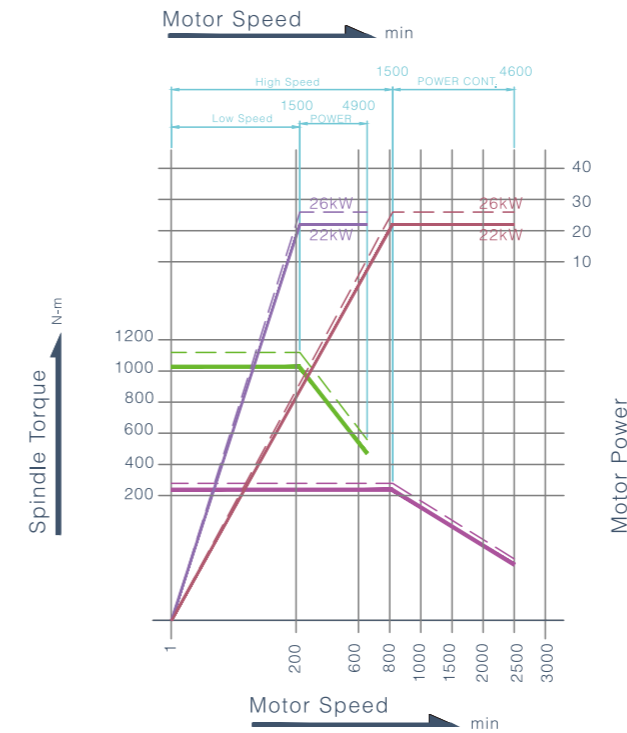

Spindle: A2-15
Spindle bore: $\Phi 180\text{mm}$
Spindle gearbox: 2-speed
Spindle motor: $\alpha 22i(22/26\text{kW})$

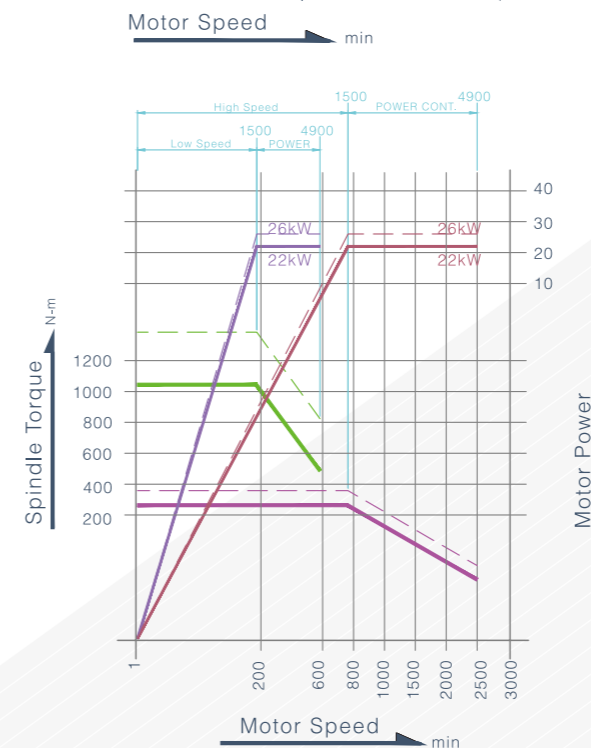

Spindle Torque
Motor Speed
Low speed 30min. operation zone
High speed 30min. operation zone
Low speed continuous operation zone
High speed continuous operation zone

SPINDLE OUTPUT / TORQUE DIAGRAM

TC-45

Spindle: A2-11
 Spindle bore: $\Phi 160\text{mm}$
 Spindle gearbox: 3-speed
 Spindle motor: $\alpha 30i(30/37\text{kW})$

Spindle: A2-15
 Spindle bore: $\Phi 230\text{mm}$
 Spindle gearbox: 3-speed
 Spindle motor: $\alpha 30i(30/37\text{kW})$

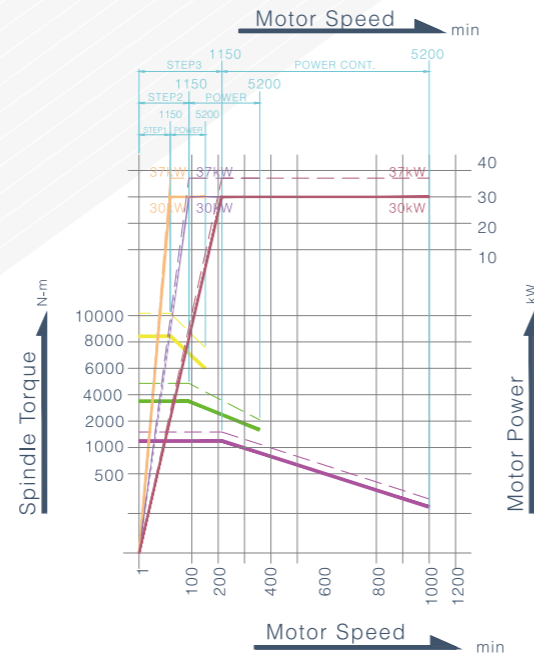
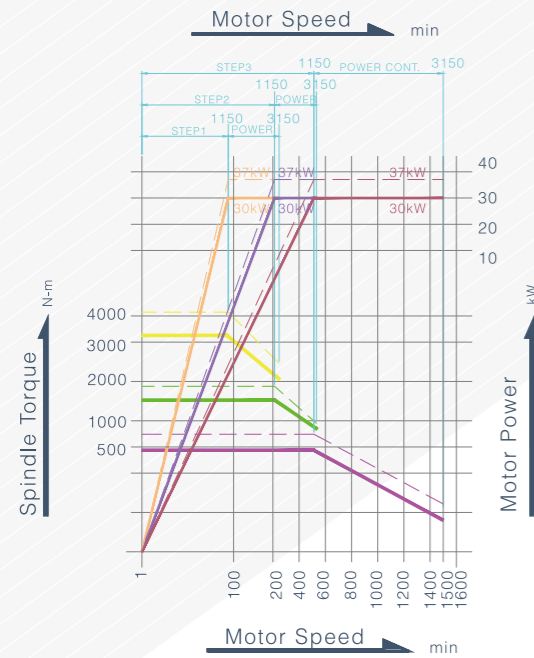

Spindle Torque
 Motor Power
 STEP1-30min. operation zone
 STEP2-30. operation zone
 STEP3-30. operation zone
 STEP4-Continuous
 STEP5-Continuous
 STEP6-Continuous

Spindle Torque
 Motor Power
 STEP1-30min. operation zone
 STEP2-30. operation zone
 STEP3-30. operation zone
 STEP4-Continuous
 STEP5-Continuous
 STEP6-Continuous

TC-50

A2-11 a40i+Gear box P-T Chat
 1-STEP RAITO: 0.0348
 2-STEP RAITO: 0.0811
 3-STEP RAITO: 0.1323
 4-STEP RAITO: 0.3087

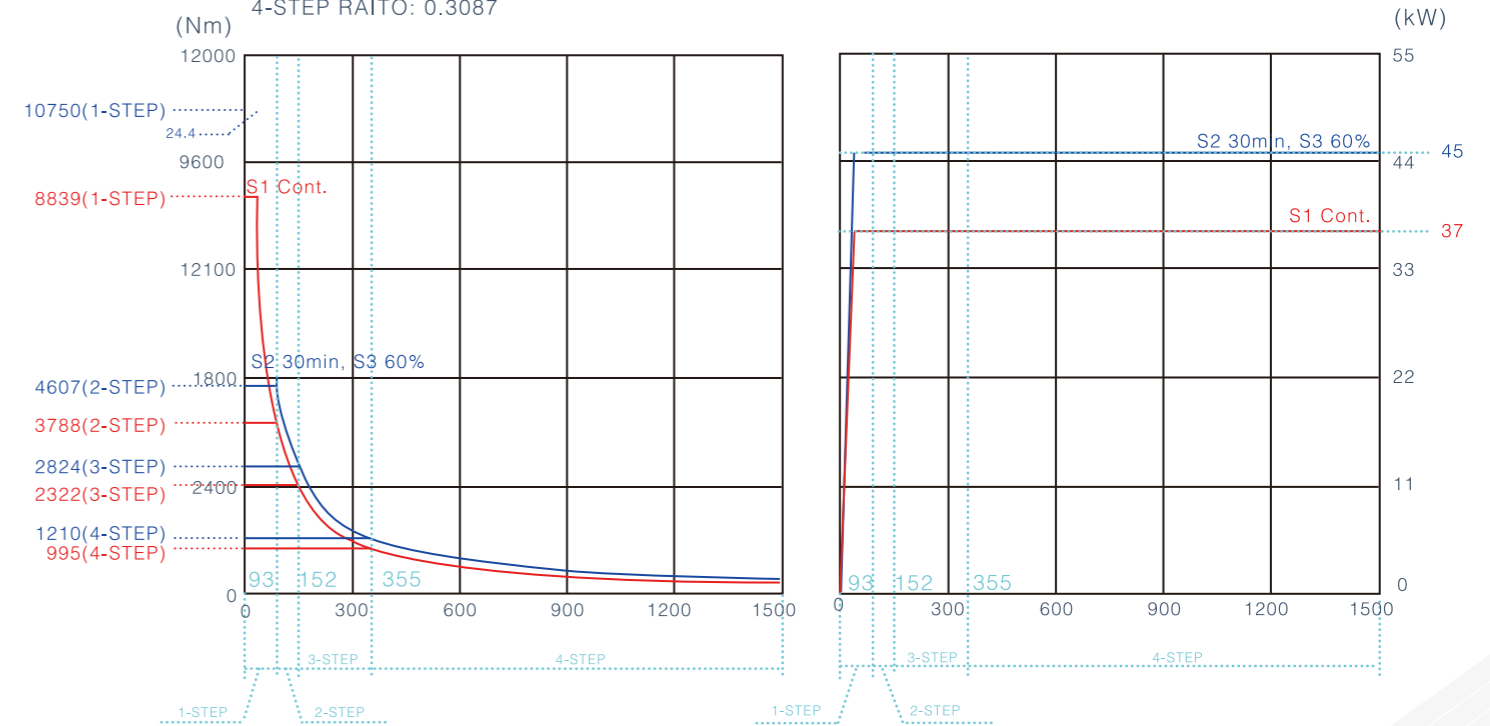

SPINDLE SPEED (rpm)

TC-45

Spindle: A2-20
 Spindle bore: $\Phi 320\text{mm}$
 Spindle gearbox: 3-speed
 Spindle motor: $\alpha 30i(30/37\text{kW})$

Spindle: A2-20
 Spindle bore: $\Phi 360\text{mm}$
 Spindle gearbox: 2-speed
 Spindle motor: $\alpha 30i(30/37\text{kW})$

A2-15 a40i+Gear box P-T Chat
 1-STEP RAITO: 0.0223
 2-STEP RAITO: 0.0520
 3-STEP RAITO: 0.0849
 4-STEP RAITO: 0.1981

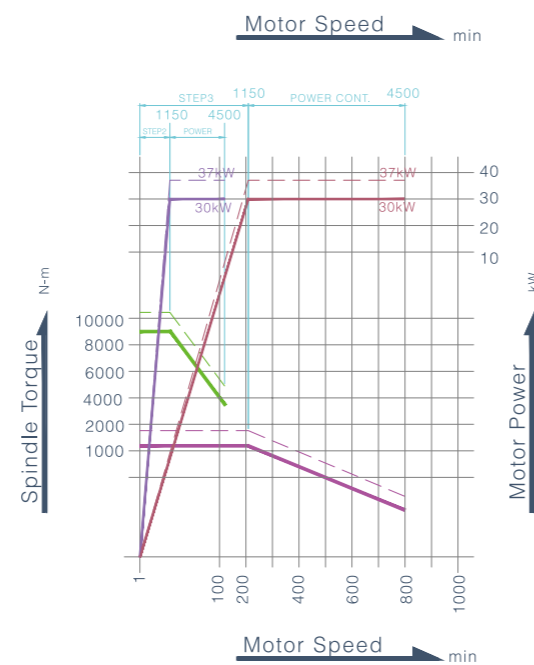
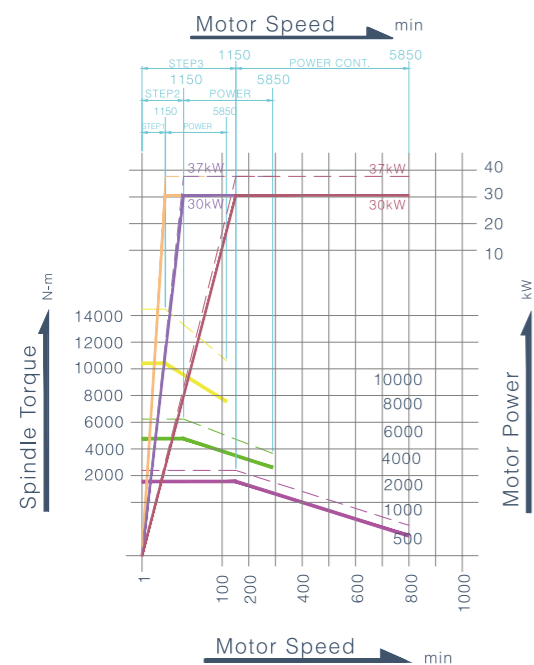

Spindle Torque
 Motor Power
 STEP1-30min. operation zone
 STEP2-30. operation zone
 STEP3-30. operation zone
 STEP4-Continuous
 STEP5-Continuous
 STEP6-Continuous

Spindle Torque
 Motor Power
 STEP1-30min. operation zone
 STEP2-30. operation zone
 STEP3-30. operation zone
 STEP4-Continuous
 STEP5-Continuous
 STEP6-Continuous

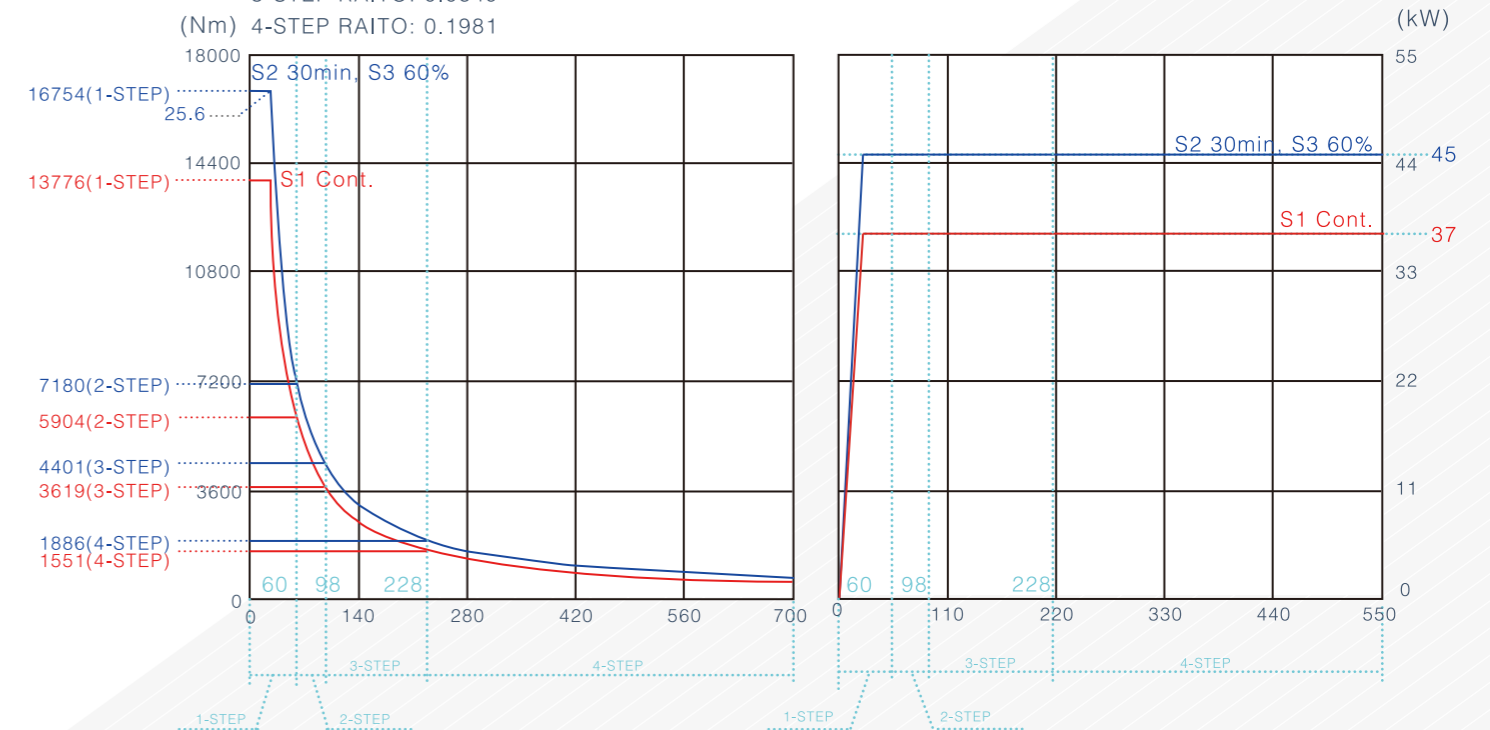

SPINDLE SPEED (rpm)

SPINDLE OUTPUT / TORQUE DIAGRAM

TC-50

A2-20 a40i+Gear box P-T Chat
 1-STEP RAITO: 0.0212
 2-STEP RAITO: 0.0495
 3-STEP RAITO: 0.0808
 4-STEP RAITO: 0.1885

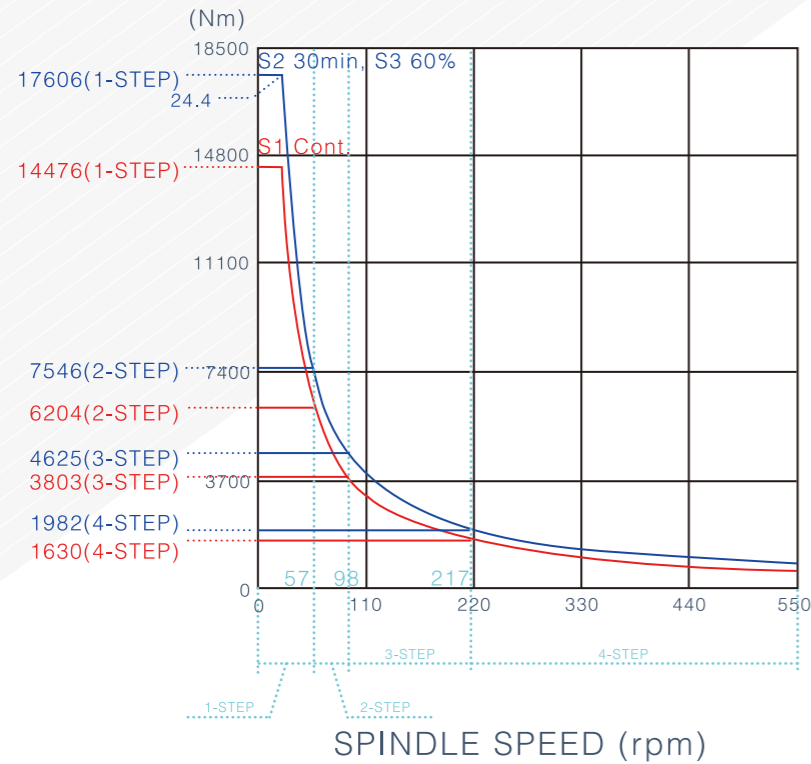

SPINDLE SPEED (rpm)

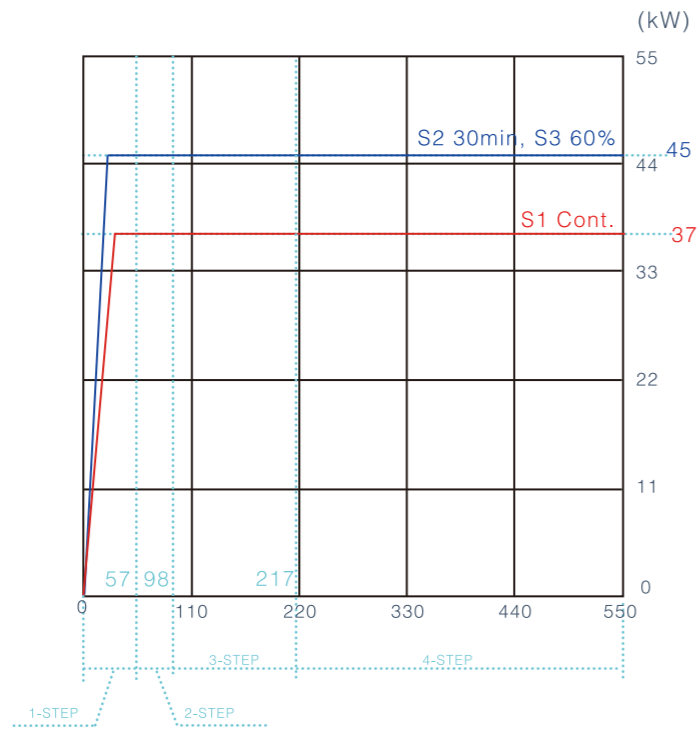

SPINDLE SPEED (rpm)

- All specification, design and characteristics shown on this catalogue are subject to change without prior notice.

TC SPECIFICATIONS

MODEL	ITEM	UNIT	TC-35		
			TC-35L08	TC-35L15	TC-35L23
Capacity	Swing over bed	mm(in)	Ø660 (25.98")		
	Swing over cross slide	mm(in)	Ø480 (18.9")		
	Max turning diameter	mm(in)	Ø500 (19.68")		
	Spindle nose between center	mm(in)	943 (37.13")	1703 (67.05")	2463 (96.85")
	Working length	mm(in)	Following working length are based on A2-8, 12" hydraulic 3 jaw hollow chuck		
Spindle	Spindle nose	ISO	STD.: A2-8 / OPT.: A2-11		
	Spindle bore	mm(in)	STD.: Ø105 (4.13") / OPT.: A2-11: Ø131 (5.15"), Ø165 (6.5")		
	Bar capacity	mm(in)	STD.: Ø89 (3.5") / OPT.: A2-11: Ø117 (4.6"), Ø142 (5.6")		
	Max. spindle speed	rpm	STD.: 2500 / OPT.: 2000, 1650		
	Spindle gearbox step		2		
	Living tools speed	rpm	OPT.: 0 ~ 3000		
Chuck	Hydraulic chuck size	mm(in)	STD.: ø305 (12") / OPT.: ø380 (15")		
Turret	Station	Station	STD.: 12		
	O.D. tooling	mm(in)	STD.: 32 (1.25")		
	I.D. tooling	mm(in)	Ø50 (2")		
X/Z axis	X axis travel	mm(in)	250+25 (9.84"+1")		
	Z axis travel	mm(in)	860 (33.85")	1620 (63.78")	2380 (93.7")
	Rapid speed (X axis)	m/min	12		
	Rapid speed (Z axis)	m/min	15 / 15 / 15		
	Cutting feed rate	mm/min	0.001 ~ 500		
Motor	Spindle (cont. / 30 min.)	kW(HP)	22 (29.5) / 26 (34.9)		
	X axis	kW(HP)	4 (5.3)		
	Z axis	kW(HP)	4 (5.3)		
	Hydraulic pump	kW(HP)	2.2 (3)		
	Coolant pump	kW(HP)	0.75 (1)		
Tailstock	Type	—	Programmable		
	Tailstock travel	mm(in)	650 (25.59")	1410 (55.51")	2170 (85.43")
	Quill type	—	STD.: Stable / OPT.: Revolve		
	Quill stroke	mm(in)	100 mm (3.94")		
	Quill dia.	mm(in)	Ø110 mm (4.33")		
	Taper of center	MT	NO.5		
Tank capacity	Hydraulic	Litres	80		
	Coolant tank	Litres	480	580	680
Dimension	L*W*H	mm(in)	5304x2130x2235 208.81"x83.85"x88"	6064x2130x2235 238.74"x83.85"x88"	6824x2130x2235 268.66"x83.85"x88"
	NW/GW	kgs	10030/11140	11300/13160	13700/15700

- All specification, design and characteristics shown on this catalogue are subject to change without prior notice.

TC SPECIFICATIONS

MODEL	ITEM	UNIT	TC-35				
			TC-35L30	TC-35L40	TC-35L50	TC-35L60	TC-35L70
Capacity	Swing over bed	mm(in)	Ø660 (25.98")				
	Swing over cross slide	mm(in)	Ø480 (18.9")				
	Max turning diameter	mm(in)	Ø500 (19.68")				
	Spindle nose between center	mm(in)	3223 (126.89")	4223 (166.26")	5223 (205.63")	6223 (245")	7223(284.37")
	Working length	mm(in)	Following working length are based on A2-8, 12" hydraulic 3 jaw hollow chuck				
			3040 (119.68")	4040 (159.05")	5040 (198.42")	6040 (237.79")	7040(277.16")
Spindle	Spindle nose	ISO	STD.: A2-8 / OPT.: A2-11				
	Spindle bore	mm(in)	STD.: Ø105 (4.13") / OPT.: A2-11: Ø131 (5.15"), Ø165 (6.5")				
	Bar capacity	mm(in)	STD.: Ø89 (3.5") / OPT.: A2-11: Ø117 (4.6"), Ø142 (5.6")				
	Max. spindle speed	rpm	STD.: 2500 / OPT.: 2000, 1650				
	Spindle gearbox step		2				
	Living tools speed	rpm	OPT.: 0 ~ 3000				
Chuck	Hydraulic chuck size	mm(in)	STD.: 305 (12") / OPT.: 381 (15") 381 (15") / 457 (18")				
Turret	Station	Station	STD.: 12				
	O.D. tooling	mm(in)	STD.: 32 (1.25")				
	I.D. tooling	mm(in)	Ø50 (2")				
X/Z axis	X axis travel	mm(in)	250+25 (9.84"+1")				
	Z axis travel	mm(in)	3140 (123.62")	4140 (163")	5140 (202.36")	6140 (241.73")	7140 (281.10")
	Rapid speed (X axis)	m/min	12				
	Rapid speed (Z axis)	m/min	12 / 8 / 8 / 8 / 8				
	Cutting feed rate	mm/min	0.001 ~ 500				
Motor	Spindle (cont. / 30 min.)	kW(HP)	22 (29.5) / 26 (34.9)				
	X axis	kW(HP)	4 (5.3)				
	Z axis	kW(HP)	4 (5.3)				
	Hydraulic pump	kW(HP)	2.2 (3)				
	Coolant pump	kW(HP)	0.75 (1)				
Tailstock	Type	—	Programmable				
	Tailstock travel	mm(in)	2930 (115.35")	3930 (154.72")	4930 (194.09")	5930 (233.46")	6930 (272.83")
	Quill type	—	STD.: Stable / OPT.: Revolve				
	Quill stroke	mm(in)	100 mm (3.94")				
	Quill dia.	mm(in)	Ø110 mm (4.33")				
	Taper of center	MT	NO.5				
Tank capacity	Hydraulic	Litres	80				
	Coolant tank	Litres	780	910	1040	1170	1350
Dimension	L*W*H	mm(in)	7584x2290x2565	8155x2290x2565	9300x2290x2526	10325x2290x2565	11700x2290x2565
			298.58"x90.16"x100.98"	321.06"x90.16"x100.98"	366.14"x90.16"x100.98"	406.5"x90.16"x100.98"	460.5"x90.16"x100.98"
	NW/GW	kgs	16300/18700	17500/19200	19000/21000	21000/23000	24500/26500

- All specification, design and characteristics shown on this catalogue are subject to change without prior notice.

TC-40							
TC-40L08	TC-40L15	TC-40L23	TC-40L30	TC-40L40	TC-40L50	TC-40L60	TC-40L70
Ø850 (33.45")							
Ø660 (26")							
Ø710 (27.95")							
943 (37.13")	1703 (67.05")	2463 (96.85")	3223 (126.89")	4223 (166.26")	5223 (205.63")	6223 (245")	7223 (284.37")
Following working length are based on A2-8, 12" hydraulic 3 jaw hollow chuck							
760 (29.92")	1520 (59.8")	2280 (89.76")	3040 (119.68")	4040 (159.05")	5040 (198.42")	6040 (237.79")	7040 (277.16")
STD.: A2-8 / OPT.: A2-11 / A2-15							
STD.: Ø105 (4.13") / OPT.: A2-11: Ø131 (5.15"), Ø165 (6.5") / A2-15: Ø180 (7.08")							
STD.: Ø89 (3.5") / OPT.: A2-11: Ø117 (4.6"), Ø142 (5.6") / A2-15: Ø166 (6.53")							
STD.: 2500 / OPT.: 2000, 1650 / 1300							
2							
OPT.: 0 ~ 3000							
STD.: 305 (12") / OPT.: 381 (15") 381 (15") / 457 (18")							
STD.: 12							
STD.: 32 (1.25")							
Ø50 (2")							
355+25 (13.97"+1")							
860 (33.85")	1620 (63.78")	2380 (93.7")	3140 (123.62")	4140 (163")	5140 (202.36")	6140 (241.73")	7140 (281.10")
12							
15 / 15 / 15 / 10 / 8 / 8 / 8 / 8							
0.001 ~ 500							
22 (29.5) / 26 (34.9)							
4 (5.3)							
4 (5.3)							
2.2 (3)							
0.75 (1)							
Programmable							
650 (25.59")	1410 (55.51")	2170 (85.43")	2930 (115.35")	3930 (154.72")	4930 (194.09")	5930 (233.46")	6930 (272.83")
STD.: Stable / OPT.: Rvolve							
100 mm (3.94")							
STD.: Ø110 mm (4.33") / OPT.: Ø160 mm (6.29")							
NO.5							
80							
480	580	680	780	910	1040	1170	1350
5304x2130x2235	6064x2130x2235	6824x2130x2235	7584x2290x2565	8155x2290x2565	9300x2290x2565	10325x2290x2565	11700x2290x2565
208.81"x83.85"x88"	238.74"x83.85"x88"	268.66"x83.85"x88"	298.58"x90.16"x100.98"	321.06"x90.16"x100.98"	366.14"x90.16"x100.98"	406.5"x90.16"x100.98"	460.5"x90.16"x100.98"
11500/11950	12100/13700	15600/16800	17900/19200	19500/21500	21200/23000	23000/25000	26500/28500

- All specification, design and characteristics shown on this catalogue are subject to change without prior notice.

TC SPECIFICATIONS

MODEL	ITEM	UNIT	TC-45					
			TC-45L12	TC-45L17	TC-45L22	TC-45L32	TC-45L42	TC-45L52
Capacity	Swing over bed	mm(in)	Ø970 (38.1")					
	Swing over cross slide	mm(in)	Ø720 (28.3")					
	Max turning diameter	mm(in)	Ø850 (33.4")					
	Spindle nose between center	mm(in)	1570 (61.81")	2070 (81.5")	2570 (101.18")	3530 (138.98")	4470 (175.98")	5470 (215.35")
	Working length	mm(in)	Following working length are based on optional item A2-11, 15" hydraulic 3 jaw hollow chuck					
			1130 (44.48")	1630 (64.17")	2130 (83.85")	3090 (121.65")	4030 (158.66")	5030 (198.03")
Spindle	Spindle nose	ISO	STD.: A2-11 / OPT.: A2-15 / A2-20					
	Spindle bore	mm(in)	STD.: Ø160 (6.3") / OPT.: A2-15: Ø230 (9") / A2-20: Ø320 (12.59"), Ø360 (14.17")					
	Bar capacity	mm(in)	OPT.: A2-11: Ø142 (5.6") , A2-15: Ø205 (8.07") / A2-20: Deped. On Chuck					
	Max. spindle speed	rpm	STD.: 1500 / OPT.: 700, 550, 450					
	Spindle gearbox step		3					
	Living tools speed	rpm	OPT.: 0 ~ 3000					
Chuck	Hydraulic chuck size	mm(in)	OPT.: 381 (15") / 610 (24") / --- , ---					
Turret	Station	Station	12					
	O.D. tooling	mm(in)	32 (1.25")					
	I.D. tooling	mm(in)	Ø50 (2")					
X/Z axis	X axis travel	mm(in)	425+25 (16.7"+1")					
	Z axis travel	mm(in)	1250 (49.21")	1750 (68.89")	2250 (88.58")	3210 (126.37")	4150 (163.38")	5150 (202.75")
	Rapid speed (X axis)	m/min	12					
	Rapid speed (Z axis)	m/min	15 / 15 / 15 / 10 / 8 / 8					
	Cutting feed rate	mm/min	0.001 ~ 500					
Motor	Spindle (cont. / 30 min.)	kW(HP)	30 (40) / 37 (39)					
	X axis	kW(HP)	4 (5.4)					
	Z axis	kW(HP)	7 (9.4)					
	Hydraulic pump	kW(HP)	3.75 (5)					
	Coolant pump	kW(HP)	0.75 (1)					
Tailstock	Type	—	Programmable					
	Tailstock travel	mm(in)	950 (37.4")	1450 (57")	1950 (76.7")	2910 (114.56")	3850 (151.57)	4850 (190.94)
	Quill type	—	STD.: Stable / OPT.: Revolve					
	Quill stroke	mm(in)	160 mm (6.3")					
	Quill dia.	mm(in)	Ø160 mm (6.3")					
	Taper of center	MT	NO.6					
Tank capacity	Hydraulic	Litres	80					
	Coolant tank	Litres	520	600	670	810	950	1050
Dimension	L*W*H	mm(in)	6160x2230x2445	6660x2230x2445	7160x2230x2445	8160x2390x2775	9160x2390x2775	10160x2390x2775
			242.5"x87.7"x96.2"	262.2"x87.7"x96.2"	281.1"x87.8"x96.2"	321"x94.09"x109.25"	360.1"x94.09"x109.25"	400.1"x94.09"x109.25"
	NW/GW	kgs	14200/15000	14950/15700	15700/16700	18400/19900	20100/22100	21900/23700

- All specification, design and characteristics shown on this catalogue are subject to change without prior notice.

TC-45		TC-50					
TC-45L62	TC-45L72	TC-50L22	TC-50L32	TC-50L42	TC-50L52	TC-50L62	TC-50L72
		Ø1100 (43")					
		Ø940 (37")					
		Ø1020 (40")					
6470 (254.72")	7470 (294.1")	2380 (90.7")	3370 (132.68")	4300 (169.29")	5290 (208.27")	6290 (247.64")	7290 (287.01")
Following working length are based on optional item A2-11, 15" hydraulic 3 jaw hollow chuck							
6030 (237.4")	7030 (276.77")	2150 (86.65")	3140 (123.62")	4075 (160.43")	5055 (199.02")	6055 (238.39")	7055 (277.76")
		STD.: A2-11 / OPT.: A2-15 / A2-20					
		STD.: Ø160 (6.3") / OPT.: A2-15: Ø230 (9") / A2-20: Ø320 (12.59"), Ø360 (14.17")					
		OPT.: A2-11: Ø142 (5.6") , A2-15: Ø205 (8.07") / A2-20: Deped. On Chuck					
		STD.: 1500 / OPT.: 700, 550, 450					
		4					
		OPT.: 0 ~ 3000					
		OPT.: 381 (15") / 610 (24") / --- , ---					
		12					
		32 (1.25")					
		Ø50 (2")					
		510+25 (20"+1")					
6150 (242.13")	7150 (281.5")	2260 (88.97")	3220 (126.77")	4090 (161.02")	5070 (199.61")	6070 (238.98")	7070 (238.98")
		12					
8 / 8		15 / 10 / 8 / 8 / 8 / 8					
		500					
		37 (49.6) / 45 (60.3)					
		4 (5.4)					
		7 (9.4)					
		3.75 (5)					
		0.75 (1)					
		Programmable					
5850 (230.31)	6850 (269.69)	1900 (74.8")	2900 (114.17")	3900 (153.54")	4900 (192.91")	5900 (232.28")	6900 (271.65")
		STD.: Stable / OPT.: Revolve					
		200 mm (7.87")					
		Ø200 mm (7.87")					
		NO.6					
		80					
	1150	1250	670	810	950	1050	1150
	11160x2465x2850	12160x2540x2925	8700x3158x3050	9700x3318x3380	10700x3318x3380	11700x3318x3380	12700x3393x3455
	439.4"x97.05"x112.2"	439.4"x97.05"x112.2"	342.51"x124.33"x124"	381.88"x130.63"x133.07"	421.25"x130.63"x133.07"	460.62"x130.63"x133.07"	500"x133.58"x136.02"
	23700/25500	25500/27300	18000/20000	23000/27000	27000/31000	32000/36000	37000/41000
							42000/46000

- All specification, design and characteristics shown on this catalogue are subject to change without prior notice.

TC-Y SPECIFICATIONS

MODEL	ITEM	UNIT	TC-40Y		
			TC-40YL08	TC-40YL15	TC-40YL23
Capacity	Swing over bed	mm(in)	Ø850 (33.45")		
	Swing over cross slide	mm(in)	Ø660 (261")		
	Max turning diameter	mm(in)	Ø530 (20.87")		
	Spindle nose between center	mm(in)	943 (37.13")	1703 (67.05")	2463 (96.85")
	Working length	mm(in)	682 (26.85")	1442 (56.77")	2202 (86.69")
Spindle	Spindle nose	ISO	STD.: A2-8 / OPT.: A2-11 / A2-15		
	Spindle bore	mm(in)	STD.: Ø105 (4.13") / OPT.: A2-11: Ø131 (5.15"), Ø165 (6.5") / A2-15: Ø180 (7.08")		
	Bar capacity	mm(in)	STD.: Ø89 (3.5") / OPT.: A2-11: Ø117 (4.6"), Ø142 (5.6") / A2-15: Ø166 (6.53")		
	Max. spindle speed	rpm	STD.: 2500 / OPT.: 2000, 1650 / 1300		
	Spindle gearbox step		2		
Turret	Turret type	-	VDI 40		
	Tool station	-	12 Tools		
	O.D. Tooling	mm(in)	25 (1")		
	I.D. Tooling	mm(in)	40 (1.5")		
	Living tools speed	rpm	4000		
X/Y/Z axis	X axis travel	mm(in)	265+55 (10.43"+2.17")		
	Y axis travel	mm(in)	±80 (3.15")		
	Z axis travel	mm(in)	783 (30.83")	1543 (60.75")	2303 (90.67")
	Rapid speed (X axis)	m/min	12		
	Rapid speed (Y axis)	m/min	8		
	Rapid speed (Z axis)	m/min	15 / 15 / 15		
	Cutting feed rate	mm/min	0.001 ~ 500		
Motor	Main Spindle (30 min. Rating)	kW(HP)	22 (29.5) / 26 (34.9)		
	X Axis	kW(HP)	4 (5.3)		
	Z Axis	kW(HP)	4 (5.3)		
	Y Axis	kW(HP)	1.6 (2.15)		
	Hydraulic pump	kW(HP)	2.2 (3)		
	Coolant pump	W(HP)	0.75 (1)		
Tailstock	Type	-	Programmable		
	Tailstock travel	mm(in)	687 (27.05")	1447 (56.97")	2207 (86.89")
	Quill type	-	STD.: Stable / OPT.: Rvolve		
	Quill stroke	mm(in)	100 (3.94")		
	Quill dia.	mm(in)	STD.: Ø110 (4.33") / OPT.: Ø160 (6.29")		
Taper of center	MT	NO.5			
Tank capacity	Hydraulic	Litres	80		
	Coolant tank	Litres	4800	580	680
Dimension	L*W*H	mm(in)	3800x2200x2650	4500x2200x2650	5300x2200x2650
			149.6"x86.6"x104.3"	177.2"x86.6"x104.3"	208.7"x86.6"x104.3"
	NW/GW	kgs	13000/13450	14500/16000	16000/17500

- All specification, design and characteristics shown on this catalogue are subject to change without prior notice.

TC-40Y				
TC-40YL30	TC-40YL40	TC-40YL50	TC-40YL60	TC-40YL70
Ø850 (33.45")				
Ø660 (261")				
Ø530 (20.87")				
3223 (126.89")	4223 (166.26")	5223 (205.63")	6223 (245")	7223 (284.37")
2962 (116.61")	3962 (155.98")	4962 (195.35")	5962 (234.72")	6962 (274.09")
STD.: A2-8 / OPT.: A2-11 / A2-15				
STD.: Ø105 (4.13") / OPT.: A2-11: Ø131 (5.15"), Ø165 (6.5") / A2-15: Ø180 (7.08")				
STD.: Ø89 (3.5") / OPT.: A2-11: Ø117 (4.6"), Ø142 (5.6") / A2-15: Ø166 (6.53")				
STD.: 2500 / OPT.: 2000, 1650 / 1300				
2				
VDI 40				
12 Tools				
25 (1")				
40 (1.5")				
4000				
265+55 (10.43"+2.17")				
±80 (3.15")				
3063 (120.59")	4063(159.96")	5063 (199.33")	6063 (238.7")	7063 (278.07")
12				
8				
8 / 8 / 8 / 8 / 8				
0.001 ~ 500				
22 (29.5) / 26 (34.9)				
4 (5.3)				
4 (5.3)				
1.6 (2.15)				
2.2 (3)				
0.75 (1)				
Programmable				
2967 (116.81")	3967 (156.18")	4967 (195.55")	5967 (234.92")	6967 (274.29")
STD.: Stable / OPT.: Rvolve				
100 (3.94")				
STD.: Ø110 (4.33") / OPT.: Ø160 (6.29")				
NO.5				
80				
780	910	1040	1170	1350
6000x2550x3000	7000x2550x3000	8000x2550x3000	9000x2550x3000	10375x2550x3000
236.2"x100.4"x118.11"	275.6"x100.4"x118.11"	315"x100.4"x118.11"	354.3"x100.4"x118.11"	408.46"x100.4"x118.11"
17500/19500	21000/23000	24000/25500	27100/29000	30600/32500

- All specification, design and characteristics shown on this catalogue are subject to change without prior notice.

TC-Y SPECIFICATIONS

MODEL	ITEM	UNIT	TC-45Y						
			TC-45YL12	TC-45YL17	TC-45YL22	TC-45YL32	TC-45YL42	TC-45YL52	
Capacity	Swing over bed	mm(in)	Ø1020 (40.16")						
	Swing over cross slide	mm(in)	Ø890 (35")						
	Max turning diameter	mm(in)	Ø720 (28.3")						
	Spindle nose between center	mm(in)	1570 (61.81")	2070 (81.5")	2570 (101.18")	3530 (138.98")	4470 (175.98")	5470 (215.35")	
	Working length	mm(in)	9808 (38.58")	1480 (58.27")	1980 (77.95")	2940 (115.75")	3880 (152.76")	4880 (192.13")	
Spindle	Spindle nose	ISO	STD.: A2-11 / OPT.: A2-15 / A2-20						
	Spindle bore	mm(in)	STD.: Ø160 (6.3") / OPT: A2-15: Ø230 (9") / A2-20: Ø320 (12.59"), Ø360 (14.17")						
	Bar capacity	mm(in)	OPT.: A2-11: Ø142 (5.6"), A2-15: Ø205 (8.07") / A2-20: Deped. On Chuck						
	Max. spindle speed	rpm	STD.: 1500 / OPT.: 700, 550, 450						
	Spindle gearbox step		3						
Turret	Turret type	-	VDI50						
	Tool station	-	12 Tools						
	O.D. tooling	mm(in)	32 (1.25")						
	I.D. tooling	mm(in)	Ø60 (2.36")						
	Living tools speed	rpm	4000						
X/Y/Z axis	X axis travel	mm(in)	360+50 (14.1"+1.97")						
	Y axis travel	mm(in)	±130 (5.12")						
	Z axis travel	mm(in)	1210 (47.64")	1710 (67.32")	2210 (87")	3170 (124.8")	4110 (161.81")	5110 (201.18")	
	Rapid speed (X axis)	m/min	12						
	Rapid speed (Y axis)	m/min	8						
	Rapid speed (Z axis)	m/min	15 / 15 / 15 / 10 / 8 / 8						
Motor	Cutting feed rate	mm/min	0.001 ~ 500						
	Main spindle (Continuous)	kW(HP)	30 (40) / 37 (49)						
	Main spindle (30 min. Rating)	kW(HP)	30(40) / 37 (49)						
	X axis	kW(HP)	4 (5.3)						
	Z axis	kW(HP)	7 (9.4)						
	Y axis	kW(HP)	4 (5.3)						
Tailstock	Hydraulic pump	kW(HP)	3.75 (5)						
	Coolant pump	W(HP)	0.75 (1)						
	Type	-	Programmable						
	Tailstock travel	mm(in)	900 (35.43")	1400 (55.11")	1900 (74.8")	2860 (112.6")	3800 (149.6")	4800 (188.97")	
	Quill type	-	STD.: Stable / OPT.: Rvolve						
	Quill stroke	mm(in)	160 mm (6.3")						
Tank capacity	Quill dia.	mm(in)	Ø160 mm (6.3")						
	Taper of center	MT	NO.6						
	Hydraulic	Litres	80						
	Coolant tank	Litres	520	600	670	810	950	1050	
	Dimension	L*W*H	mm(in)	5440x2250x2760	5940x2250x2760	6440x2250x3090	7440x2570x3090	8440x2570x3090	9440x2570x3090
		NW/GW	kgs	14000/14500	15550/16260	17090/18060	20200/21670	23300/25270	26400/28870

- All specification, design and characteristics shown on this catalogue are subject to change without prior notice.

TC-45Y		TC-50Y					
TC-45YL62	TC-45YL72	TC-50YL22	TC-50YL32	TC-50YL42	TC-50YL52	TC-50YL62	TC-50YL72
Ø1020 (40.16")		Ø1100 (43")					
Ø890 (35")		Ø1000 (39.3")					
Ø720 (28.3")		Ø900 (35.4")					
6470 (254.72")	7470 (294.09")	2570 (101.18")	3530 (138.98")	4470 (175.98")	5470 (215.35")	6470 (254.7")	7470 (294.1")
5880 (231.5")	6880 (270.87")	2078 (81.81")	3038 (119.60")	3978 (156.61")	4978 (195.98")	5978 (235.35")	6978 (274.7")
STD.: A2-11 / OPT.: A2-15 / A2-20		STD.: A2-11 / OPT.: A2-15 / A2-20					
STD.: Ø160 (6.3") / OPT: A2-15: Ø230 (9") / A2-20: Ø320 (12.59"), Ø360 (14.17")		STD.: Ø160 (6.3") / OPT: A2-15: Ø230 (9") / A2-20: Ø320 (12.59"), Ø360 (14.17")					
OPT.: A2-11: Ø142 (5.6"), A2-15: Ø205 (8.07") / A2-20: Deped. On Chuck		OPT.: A2-11: Ø142 (5.6"), A2-15: Ø205 (8.07") / A2-20: Deped. On Chuck					
STD.: 1500 / OPT.: 700, 550, 450		STD.: 1500 / OPT.: 700, 550, 450					
3		4					
VDI50		BMT-75					
12 Tools		12 Tools					
32 (1.25")		32 (1.25")					
Ø60 (2.36")		Ø80 (3.14")					
4000		3000					
360+50 (14.1"+1.97")		450+50 (17.7"+1.97")					
±130 (5.12")		±150 (5.9")					
6110 (240.55")	7110 (279.92")	2210 (87")	3170 (124.8")	4110 (161.81")	5110 (201.18")	6110 (240.55")	7110 (279.92")
12		12					
8 / 8		8					
15 / 15 / 15 / 10 / 8 / 8 / 8		15 / 15 / 15 / 10 / 8 / 8					
0.001 ~ 500		0.001 ~ 500					
30 (40) / 37 (49)		37 (49.6) / 45 (60.3)					
30(40) / 37 (49)		37 (49.6) / 45 (60.3)					
4 (5.3)		7 (9.4)					
7 (9.4)		7 (9.4)					
4 (5.3)		4 (5.3)					
3.75 (5)		3.75 (5)					
0.75 (1)		0.75 (1)					
Programmable		Programmable					
5740 (255.98")	6740 (265.35")	1900 (74.8")	2860 (112.6")	3800 (149.6")	4800 (188.97")	5900 (228.35")	6900 (267.72")
STD.: Stable / OPT.: Rvolve		STD.: Stable / OPT.: Rvolve					
160 mm (6.3")		200 mm (7.87")					
Ø160 mm (6.3")		Ø200 mm (7.87")					
NO.6		NO.6					
80		80					
1150	1250	670	810	950	1050	1150	1250
10440x2645x3165	11440x2720x3240	6440x2570x3090	7440x2570x3090	8440x2570x3090	9440x2570x3090	10440x2570x3090	11440x2570x3090
411"x1004.1"x124.61"	371.7"x107.1"x127.65"	253.5"x88.6"x121.65"	292.9"x101.2"x121.65"	332.3"x101.2"x121.65"	371.7"x101.2"x121.65"	411"x101.2"x121.65"	450.4"x101.2"x121.65"
29500/22470	32600/28870	18500/20000	23500/27000	27500/31000	32500/36000	27500/31000	32500/36000

- All specification, design and characteristics shown on this catalogue are subject to change without prior notice.

TC-T2/T2Y SPECIFICATIONS

MODEL	ITEM	UNIT	TC-40T2	
			TC-40T2L15	TC-40T2L23
CAPACITY	Swing over bed	mm(in)	Ø850(33.46)	Ø850(33.46)
	Swing over saddle	mm(in)	Ø560(22)	Ø560(22)
	Maxi turning dia.	mm(in)	Ø500(19.7)	Ø500(19.7)
	Working length	mm(in)	1082(42.6)	1842(72.5)
Main Spindle & Sub Spindle	spindle nose	ISO	A2-8 (OPT. A2-11/ A2-15)	
	spindle bore	mm(in)	STD. Ø105(4.13) OPT. Ø131(5.15)/ Ø165(6.5)/ Ø180(7.08)	
	Bar capacity	mm(in)	STD. Ø90(3.54) OPT. Ø117(4.6)/ Ø142(5.6)/ Ø166(6.53)	
	Range of spindle speed	rpm	STD. 2500 OPT. 2000 / 1650 / 1300	
	Living tools speed(OPT)	rpm	OPT. 4000	OPT. 4000
Chuck	Hydraulic chuck	mm(in)	STD. 305 (12") / OPT. 381 (15") 381 (15") / 457 (18")	
Turret (Upper/Lower)	Tool station (Random)	mm(in)	Servo-12T/10T	Servo-12T/10T
	O.D. tooling	station	32x32	32x32
	I.D tooling	mm(in)	Ø50(1.97)	Ø50(1.97)
Cross slide (X1/X2 Axis) & Carriage (Z1/Z2Axis)	X1, X2-axis Travel	mm(in)	290(11.4)	290(11.4)
	Y1-axis Travel	mm(in)	—	—
	Z1-axis Travel	mm(in)	1620(63.7)	2380(93.7)
	Z2-axis Travel	mm(in)	1084(42.6)	1844(72.6)
	Rapid travers speed (X1/ X2axis)	mm	12	12
	Rapid travers speed (Y1/ Y2axis)	mm	—	—
	Rapid travers speed (Z1/Z2axis)	m/min	15	15
Tailstock	Cutting feed rate(X and Z axis)	mm/min	0.001-500	0.001-500
	Type	—	Programmable	Programmable
	Tailstock travel	mm(in)	950	1710
	Quill type	—	Live	Live
	Quill stroke	mm(in)	160	160
	Quill dia.	mm(in)	160	160
Motor	Taper of center	MT	5	5
	Main Spindle(continious/30 min.)	kW(HP)	22(29.5)/26(34.9)+Gear box	22(29.5)/26(34.9)+Gear box
	X1 \ X2-axis	Kw	4(5.3) / 3(5.3)	4(5.3) / 3(5.3)
	Z1 \ Z2-axis	Kw	4(5.3) / 3(5.3)	4(5.3) / 3(5.3)
	Hydraulic oil pump	kW(HP)	3.7(5)	3.7(5)
Tank Capacity	Coolant pump	W(HP)	750(1)x2	750(1)x2
	Hydraulic Tank	Litres	80	80
Dimension	Coolant tank	Litres	580	680
	Floor space (L * W)	mm(in)	6064x2130(238.7x83.85)	6824x2130(268.6x83.85)
	Height	mm(in)	2235(88)	2235(88)
	Weight(NW/GW)	kgs	13700	16800

- All specification, design and characteristics shown on this catalogue are subject to change without prior notice.

TC-40T2	TC-40T2Y		
TC-40T2L30	TC-40T2YL15	TC-40T2YL23	TC-40T2YL30
Ø850(33.46)	Ø850(33.46)	Ø850(33.46)	Ø850(33.46)
Ø560(22)	Ø560(22)	Ø560(22)	Ø560(22)
Ø500(19.7)	Ø500(19.7)	Ø500(19.7)	Ø500(19.7)
2602(102.4)	1082(42.6)	1082(42.6)	2602(102.4)
A2-8 (OPT. A2-11/ A2-15)			
STD. Ø105(4.13) OPT. Ø131(5.15)/ Ø165(6.5)/ Ø180(7.08)			
STD. Ø90(3.54) OPT. Ø117(4.6)/ Ø142(5.6)/ Ø166(6.53)			
STD. 2500 OP. 2000 / 1650 / 1300			
OPT. 4000	4000	4000	4000
STD. 305 (12") / OPT. 381 (15") 381 (15") / 457 (18")			
Servo-12T/10T	Servo-12T/10T	Servo-12T/10T	Servo-12T/10T
32x32	32x32	32x32	32x32
Ø50(1.97)	Ø50(1.97)	Ø50(1.97)	Ø50(1.97)
290(11.4)	290(11.4)	290(11.4)	290(11.4)
—	±80	±80	±80
3140(123.6)	1620(63.7)	2380(93.7)	3140(123.6)
2604(102.5)	1084(42.6)	1844(72.6)	2604(102.5)
12	12	12	12
—	10	10	10
15	15	15	15
0.001-500	0.001-500	0.001-500	0.001-500
Programmable	Programmable	Programmable	Programmable
2470	950	1710	2470
Live	Live	Live	Live
160	160	160	160
160	160	160	160
5	5	5	5
22(29.5)/26(34.9)+Gear box	22(29.5)/26(34.9)+Gear box	22(29.5)/26(34.9)+Gear box	22(29.5)/26(34.9)+Gear box
4(5.3) / 3(5.3)	4(5.3) / 3(5.3)	4(5.3) / 3(5.3)	4(5.3) / 3(5.3)
4(5.3) / 3(5.3)	4(5.3) / 3(5.3)	4(5.3) / 3(5.3)	4(5.3) / 3(5.3)
3.7(5)	3.7(5)	3.7(5)	3.7(5)
750(1)x2	750(1)x2	750(1)x2	750(1)x2
80	80	80	80
780	580	680	780
7584x2130(298.58x83.85)	6064x2130(238.7x83.85)	6824x2130(268.6x83.85)	7584x2130(298.58x83.85)
2235(88)	2235(88)	2235(88)	2235(88)
19500	14300	17400	20100

- All specification, design and characteristics shown on this catalogue are subject to change without prior notice.

TC-TT/TTY SPECIFICATIONS

MODEL	ITEM	UNIT	TC-40TT			
			TC-40TTL23	TC-40TTL30	TC-40TTL40	TC-40TTL50
CAPACITY	Swing over bed	mm(in)	Ø850(33.46)			
	Swing over saddle	mm(in)	Ø660(25.98)			
	Maxi turning dia.	mm(in)	Ø650(25.6)			
	Working length	mm(in)	2000(79)	2780(109.4)	3670(144.4)	3670(144.4)
Main Spindle & Sub Spindle	spindle nose	mm(in)	L : ASA A2-8 · R : ASA A2-8			
	spindle bore	ISO	Ø105(4.13) / Ø90(3.54)			
	Bar capacity	mm(in)	Ø90(3.54) / Ø77(3.03)			
	Range of spindle speed	rpm	10-2500 / 10-3500			
	Living tools speed(OPT)	rpm	opt:0-3000			
Chuck	Hydraulic chuck	mm(in)	Ø304(12) / Ø254(10)			
Turret (Upper/Lower)	Tool station (Random)	mm(in)	Servo-BMT-75-12T			
	O.D. tooling	station	32x32			
	I.D tooling	mm(in)	Ø50(1.97)			
Cross slide (X1/X2 Axis) \ Carriage (Z1/Z2Axis)	X1, X2-axis Travel	mm(in)	405(15.9)			
	Y1, Y2-axis Travel	mm(in)	—			
	Z1, Z2-axis Travel	mm(in)	980(38.5)	1360(53.5)	1800(70.8)	2300(70.8)
	B-axis Travel	mm(in)	2000(78.74)	2780(109.4)	3670(144.4)	4670(144.4)
	Rapid travers speed (X1/ X2axis)	mm	12m/min			
	Rapid travers speed (Y1/ Y2axis)	mm	—			
	Rapid travers speed (Z1/Z2axis)	m/min	15m/min			
	Rapid travers speed (B-axis)	m/min	15m/min			
	Cutting feed rate(X and Z axis)	mm/min	0.001-500mm/min			
	Motor	Main Spindle(continuous)	kW(HP)	α22i+Gear box / 22kw(29.5HP)		
Main Spindle(30 min. Rating)		kW(HP)	α22i+Gear box / 26kw(34.9HP)			
Sub Spindle (continuous)		kW(HP)	α22i+Gear box / 15kw(20.1HP)			
Sub Spindle (30 min. Rating)		kW(HP)	α22i+Gear box / 18.5kw(24.8HP)			
X1 \ X2-axis		kW(HP)	α22Bi/3000 4kw(5.3HP)x2			
Z1 \ Z2-axis		kW(HP)	α22i/3000 4kw(5.3HP)x2			
B-axis		kW(HP)	α22i/3000 4kw(5.3HP)			
Hydraulic oil pump		kW(HP)	3.7kw(5HP)			
Coolant pump		W(HP)	750w(1HP)x2			
Tank Capacity	Hydraulic Tank	Litres	80			
	Coolant tank	Litres	680	780	910	1030
Dimension	Floor space (L * W)	mm(in)	6824x2130(268.6x83.85)	7584x2130(298.58x83.85)	8155x2130(338.5x83.85)	6824x2130(268.6x83.85)
	Height	mm(in)	2235(88)			
	Weight(NW/GW)	kgs	16800	19500	21800	24500

- All specification, design and characteristics shown on this catalogue are subject to change without prior notice.

STANDARD ACCESSORIES

- Spindle oil cooler (TC-45/50)
- 2-stages speed gearbox (TC-35/ 40)
- Three stages speed gear head (TC-45)
- Four stages speed gear head (TC-50)
- Servo turret + 12 stations direct type turret disc
- Manual tailstock + Stable quill + living center (TC-35)
- Programmable tailstock + Stable quill + living center (TC-40/45/50)
- Working lamp
- Heat exchanger of electric box cabinet
- 6 bar coolant pump
- Lubrication system
- Chip conveyor and bucket
- Three color alarm light
- Tool box and tool kits

TC-40TT	TC-40TTY				
	TC-40TTL50	TC-40TTYL23	TC-40TTYL30	TC-40TTYL40	TC-40TTYL60
	Ø850(33.46)				
	Ø660(25.98)				
	Ø500(23.6)				
3670(144.4)	2000(79)	2780(109.4)	3670(144.4)	3670(144.4)	3670(144.4)
	L : ASA A2-8 · R : ASA A2-8				
	Ø105(4.13) / Ø90(3.54)				
	Ø90(3.54) / Ø77(3.03)				
	10-2500 / 10-3500				
	opt:0-3000				
	Ø304(12) / Ø254(10)				
Servo-BMT-75-12T	Servo-BMT-75-12T				
	32x32				
	Ø50(1.97)				
405(15.9)	320(12.6)				
—	±80(3.15)				
2800(70.8)	980(38.5)	1360(53.5)	1800(70.8)	2300(70.8)	2800(70.8)
5670(144.4)	2000(78.74)	2780(109.4)	3670(144.4)	4670(144.4)	5670(144.4)
	12m/min				
—	10m/min				
	15m/min				
	15m/min				
	0.001-500mm/min				
	α22i+Gear box / 22kw(29.5HP)				
	α22i+Gear box / 26kw(34.9HP)				
	α22i+Gear box / 15kw(20.1HP)				
	α22i+Gear box / 18.5kw(24.8HP)				
	α22Bi/3000 4kw(5.3HP)x2				
	α22i/3000 4kw(5.3HP)x2				
	α22i/3000 4kw(5.3HP)				
	3.7kw(5HP)				
	750w(1HP)x2				
	80				
1200	680	780	910	1030	1200
11000x2130(338.5x83.85)	6824x2130(268.6x83.85)	7584x2130(298.58x83.85)	8155x2130(338.5x83.85)	9500x2130(338.5x83.85)	11000x2130(338.5x83.85)
	2235(88)				
27000	17800	20500	22800	25500	2800

- All specification, design and characteristics shown on this catalogue are subject to change without prior notice.

OPTIONAL ACCESSORIES

- Larger spindle
- Transformer
- Programmable tailstock + stable quill + living center (TC-35)
- Programmable tailstock + Rotary quill + stable center (TC-35/40/45/50)
- Automatic tool setter
- Cs /Cf axis + power turret
- Larger hydraulic chuck
- 60" height chip conveyor and bucket
- TS / CE / CSA / UKCA electric control
- Air conditioner for electrical cabinet
- Larger spindle motor
- High pressure coolant pump
- Oil mist collector
- Oil skimmer
- Manual / Hydraulic steady rest
- Sub spindle